

Thank you for selecting a DuctSox System. This guide will be helpful for the installation of an OvalSox Cable System. Sections of fabric will be labeled, assembled, bagged, and boxed for shipping. More complicated systems will include a CAD detail of the system identifying what is in each package.

NOTE: The DuctSox cable attachment (Glider) is built for 1/8" (3mm) cable only.

Overview

Inventory

The first step on any installation project is to read through this guide thoroughly and review the components that need to be installed. The best way to do this is to review the drawings of the project while reading the guide, including the CAD detail if applicable.

Shipping/Receiving

In some cases the DuctSox support system is delivered to the job site ahead of the DuctSox fabric sections. Depending on the size of a project or order, a DuctSox system will be shipped by common courier in a single brown box or several boxes. Larger orders will be shipped in crates by a common freight courier. Each DuctSox length should be packaged into individual plastic bags and labeled according to size and number of pieces. Other markings or labeling may also be incorporated for larger or more complicated systems. Be sure you have determined all boxes are accounted for.

Unpacking

Inspect shipment carefully and make sure all pieces are accounted for. Account for everything by emptying the box and examining all contents. Note any missing or damaged pieces listed on the Bill of Lading.

Labeling

Each DuctSox section will be marked with the size and section number either inside the belt of the inlet or on a tag inside the DuctSox near the zipper. The marking shall be the diameter, section length and total length. If custom labeling has been used, locate an identification sheet that will be included with the delivery.

Equipment Required:

- Drill
- Level
- Tape measure
- Marker or pencil
- Wrenches for cable clamps and eye bolts (5/16" and 9/16")
- Flat (standard) screwdriver
- Cable cutter

Component Details

Glider Attachment



Cable Stop

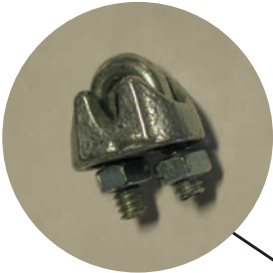

Cable Intermediate Support



Type 2 Kit

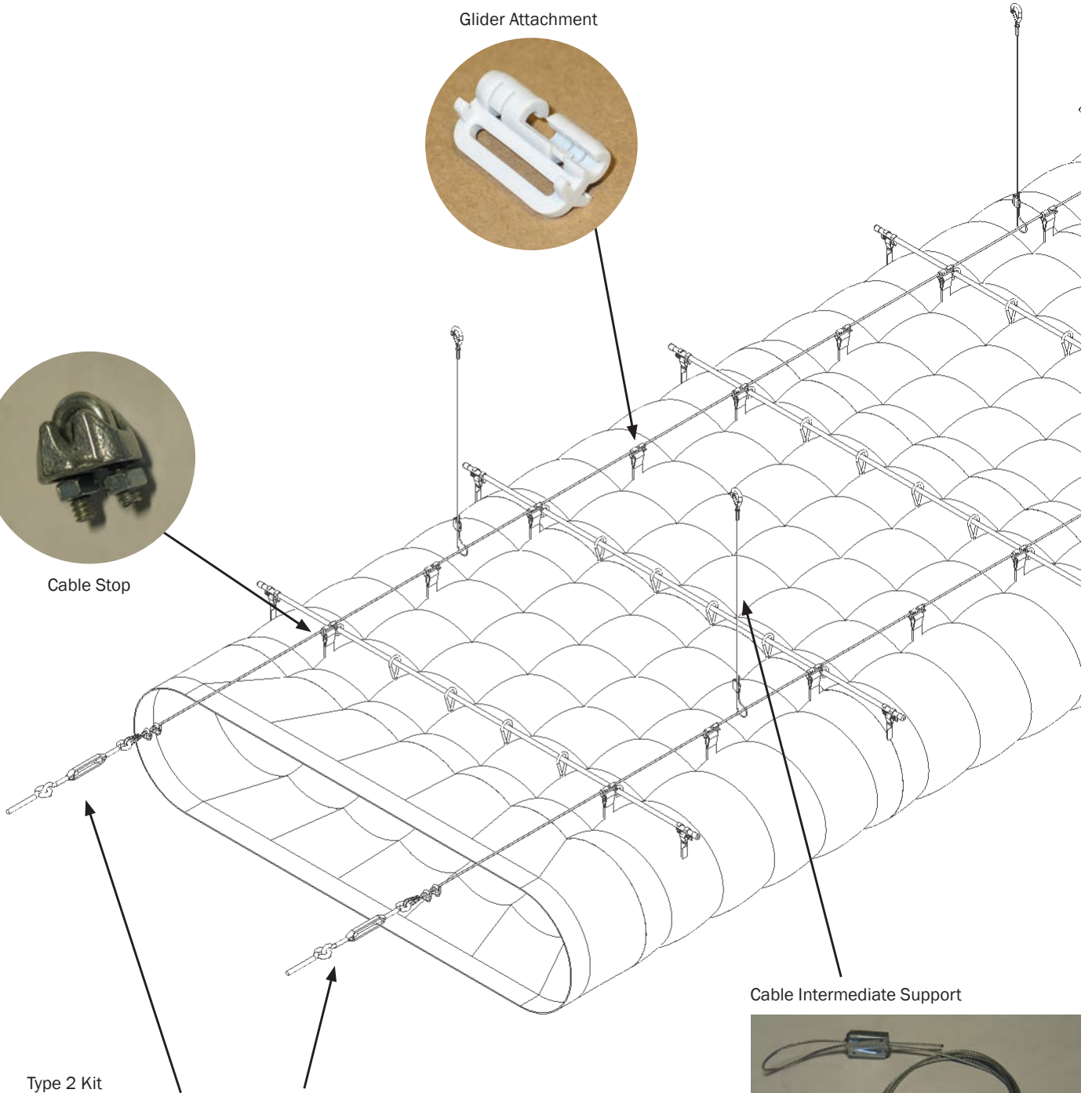

Component Details (continued)

Rod Clip

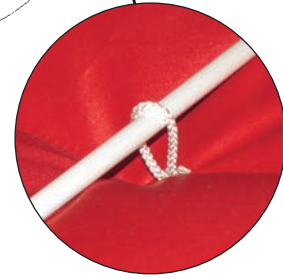
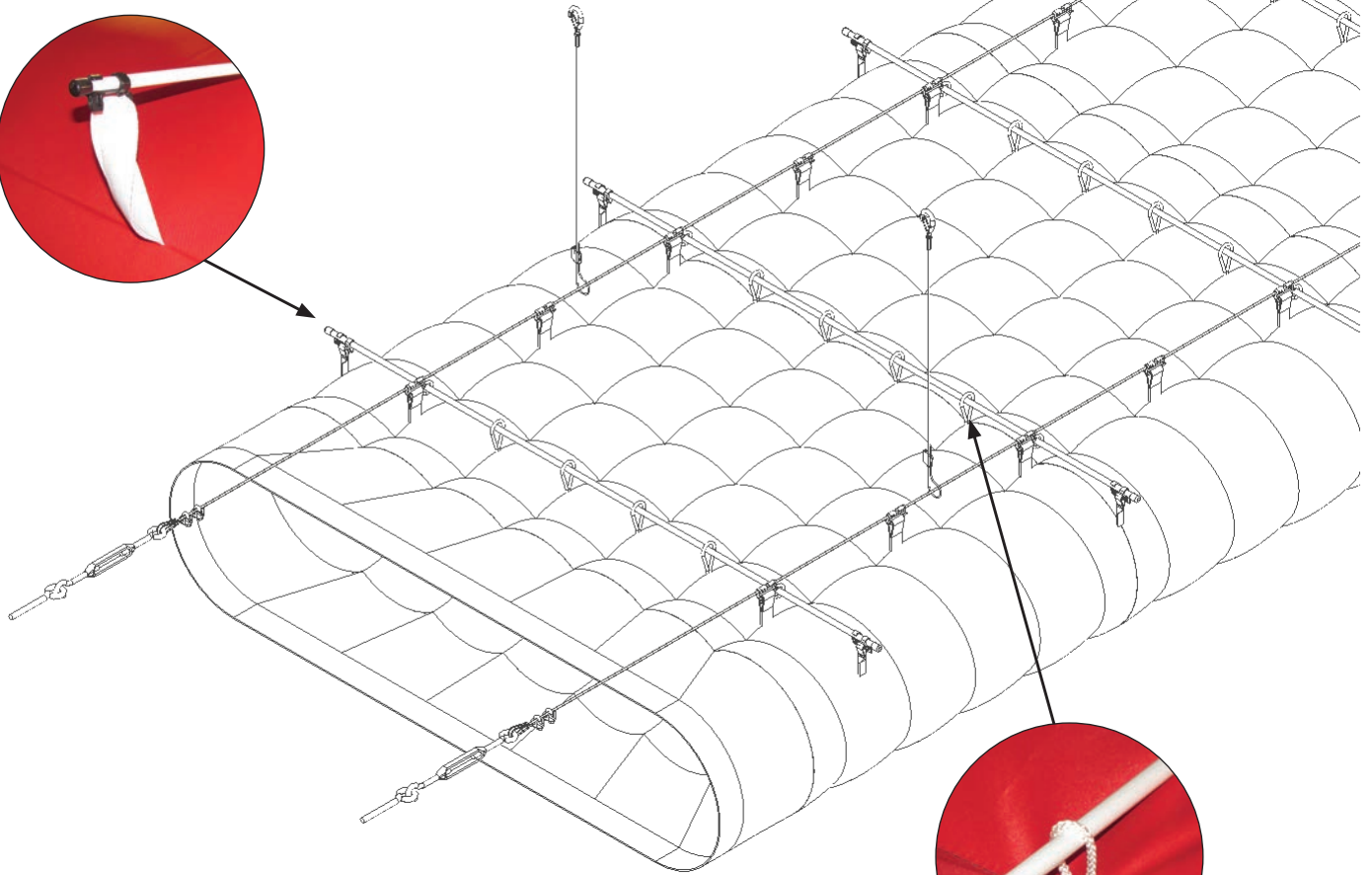

Rod Loop

OvalSox Sizing

Size (w x h)		Equivalent Round		Rod Length	
inches	mm	inches	mm	inches	mm
47 x 11	1190 x 280	24	610	47	1193
50.75 x 12	1290 x 300	26	660	50.75	1289
54.75 x 12.75	1390 x 320	28	711	54.75	1391
58.5 x 13.75	1490 x 350	30	762	58.5	1486
62.25 x 14.75	1580 x 370	32	813	62.25	1581
66.25 x 15.5	1680 x 390	34	864	66.25	1683
70 x 16.5	1780 x 420	36	914	70	1778
73.75 x 17.25	1870 x 440	38	965	73.75	1848
77.75 x 18.25	1970 x 460	40	1016	77.75	1975
81.5 x 19	2070 x 480	42	1067	81.5	2070
85.25 x 20	2170 x 510	44	1118	85.25	2165
89.25 x 21	2270 x 530	46	1168	89.25	2267
93 x 21.75	2360 x 550	48	1219	93	2362

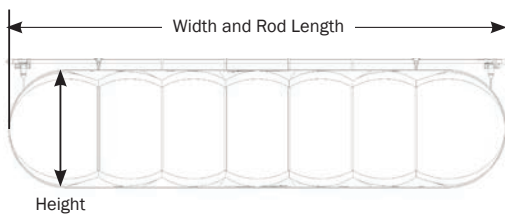

Installation Steps

1. Review materials in box, including the CAD drawing and installed location of the DuctSox
2. Prepare metal inlet collar for fabric connection
3. Mark placement and install cable.
4. Install and assemble DuctSox components
5. Start up AHU
6. Balance airflow

Step 1

Review materials in box, including the CAD drawing and installed location of the DuctSox. READ INSTRUCTIONS THOROUGHLY BEFORE BEGINNING.

Step 2

Prepare metal inlet collar for fabric connection.

- Confirm inlet air supply location.
- Confirm inlet air supply size. (Cylindrical, Rectangular, or Oval)
- DuctSox inlets are manufactured 1/2" (12mm) larger than specified to fit over metal inlet collar.
- Metal collar length should be 6" - 10" (150 to 250cm) for secure fabric attachment.
- Edge Guard (provided) should be installed on the edge of the metal collar to reduce fabric wear from the metal edge.

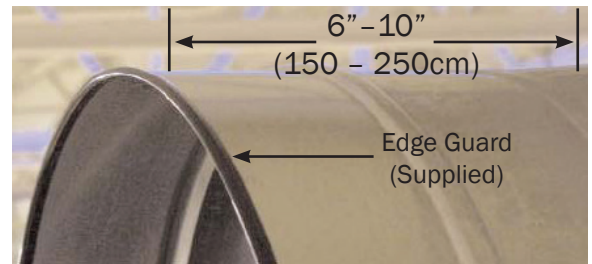

Step 3

Mark Placement and Install Cable.

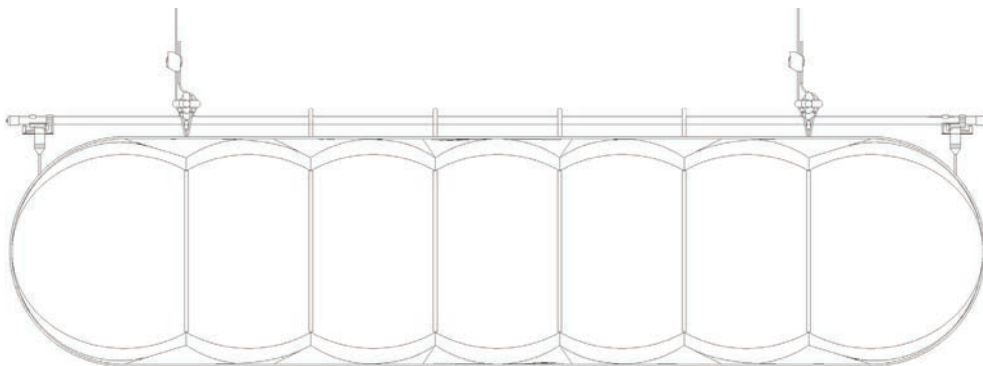

Step 3 - Details

Type 1 and Type 2 Kits

Type 1 and Type 2 kits are for straight runs of cable, 50 feet (15250mm) or less for Type 1 and Type 2 for over 50-100 feet (15250-30500mm). These kits include one 6" (153mm) turnbuckle (two for Type 2), two eyebolts, two cable thimbles, and four cable clamps.

Eye bolts must be fastened into the structure of the building by others (this could include knee braces).

Cable is fastened directly to an eyebolt with a thimble and two cable clamps. Take the cable end and thread two cable clamps onto it. Now hook the thimble onto the eyebolt. Next, thread the cable onto the thimble and through the eyebolts (cable clamps are still on the cable). Now thread the cable back into the cable clamps and tighten them.

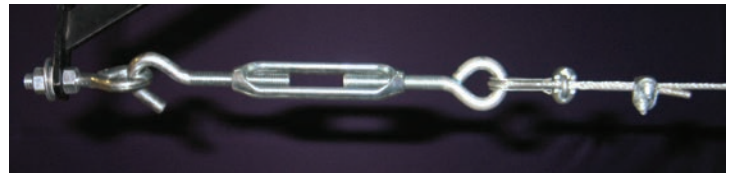

Cable is then fastened directly to the turnbuckle with a thimble and two cable clamps. Slack in the cable is taken up by the turnbuckle. If cable is still too loose after tightening the turnbuckle, loosen the cable, re-fasten cable to turnbuckle at a tighter position, and re-tighten the turnbuckle. Do not over-tighten the turnbuckle, we recommend no more than 100 lbs (445 Newtons) of tensile force.

Intermediate Support Cable

Installed every 12.5 feet (3810mm) or less to keep the DuctSox installed at a consistent elevation (reduces sag of the cable).

Standard



Pools



Step 3 – Installation

Determine placement of cable (both cable path and elevation). The cable must be located X inches apart and 1” (25mm) above the 12:00 location of the DuctSox (match this up to the chart and the drawing). Intermediate cable supports are spaced no more than 12.5 ft (3810mm).

OvalSox Size	inches	24	26	28	30	32	34	36	38	40	42	44	46	48
	mm	610	660	711	762	813	864	914	965	1016	1067	1118	1168	1219
Cable Spacing	inches	35.8	38.7	41.6	44.6	47.5	50.4	53.3	56.2	59.2	62.1	65.0	67.9	70.8
	mm	909	983	1057	1133	1207	1280	1354	1427	1504	1577	1651	1725	1798

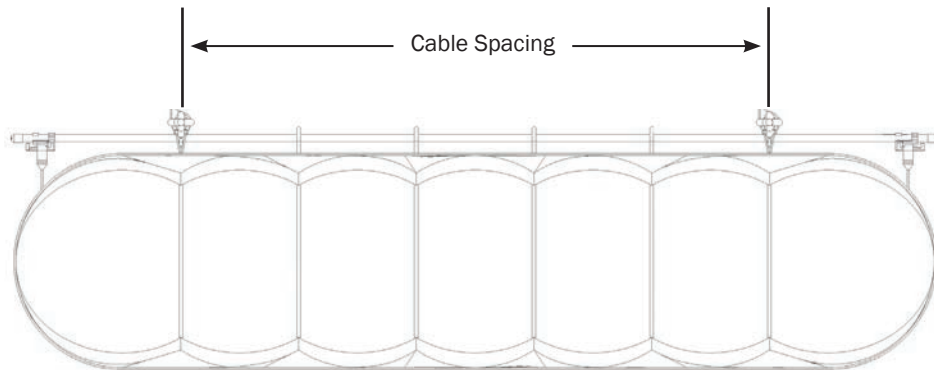

T's

There should be roughly 12” (305mm) from sidewall of DuctSox to the closest edge of any knee-bracing. Structure too close to the main run may cause premature failure due to abrasion from the structure.

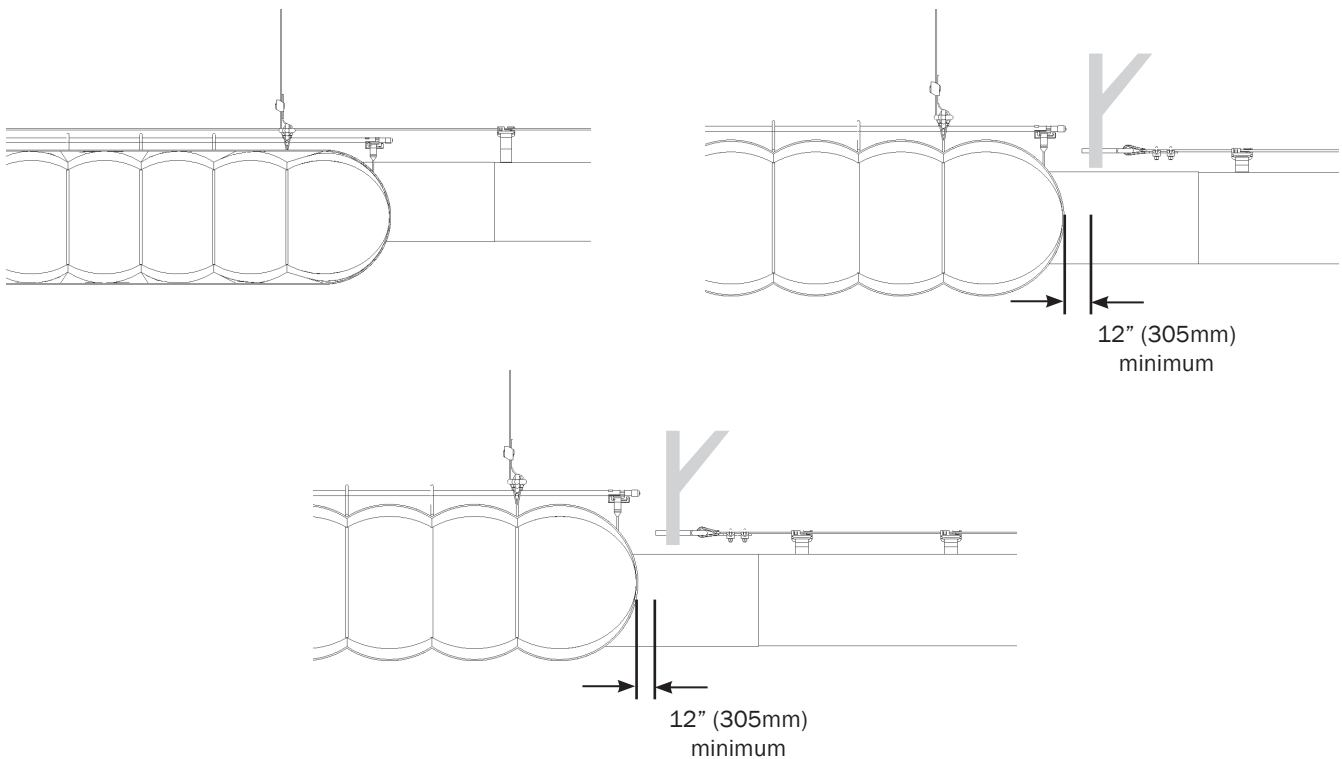

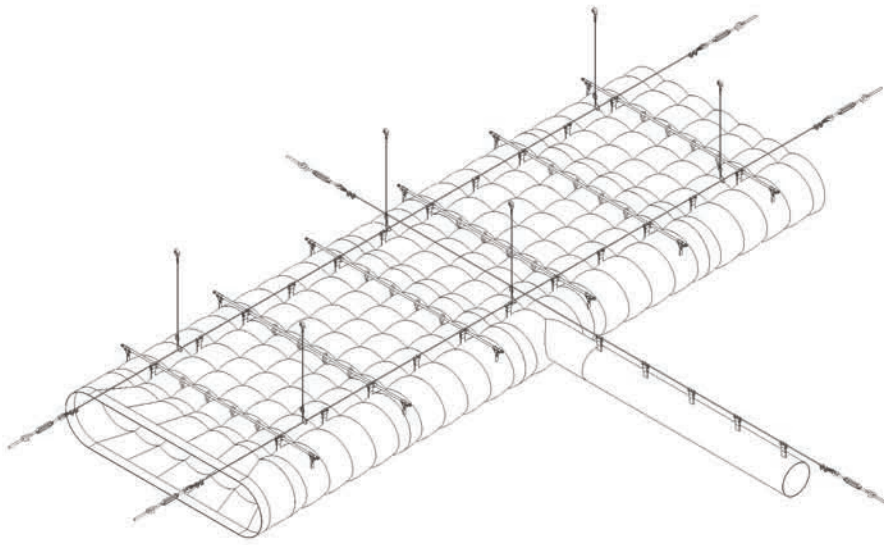

Elbows

Extended straps on heels of elbows are provided for support to cable suspension (Figure A). Vertical elbows are also supported by extended straps (Figure B).

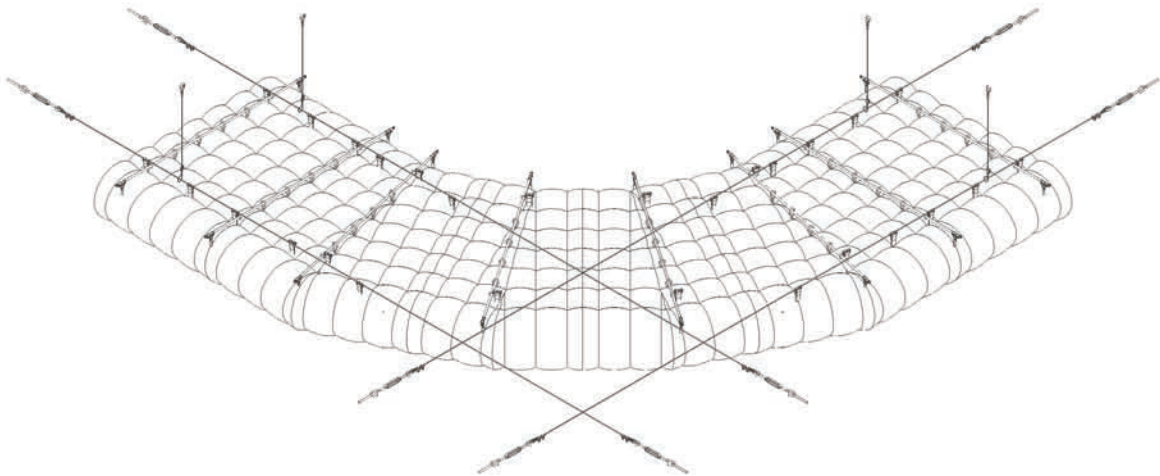

Figure A

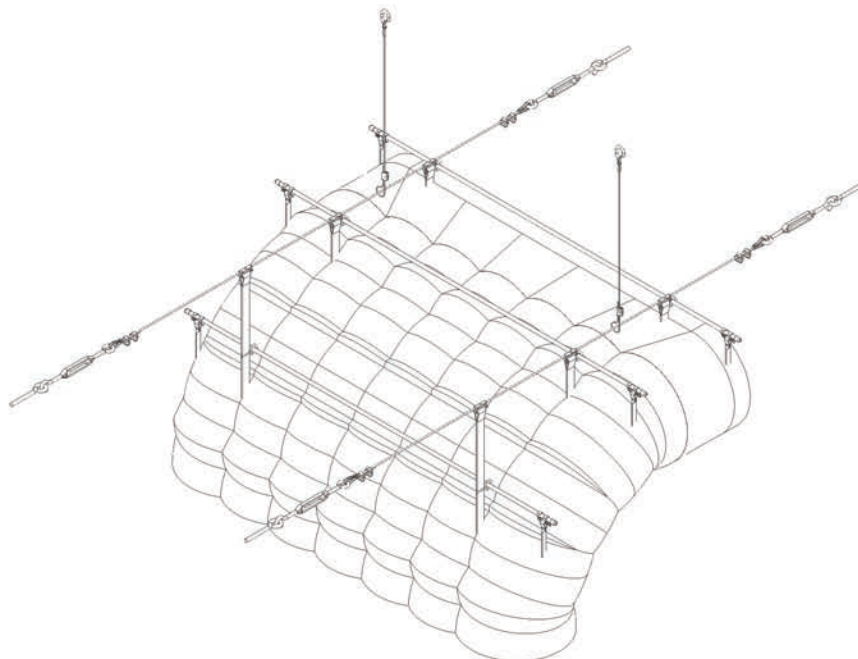

Figure B

Step 4

Install DuctSox Fabric. DuctSox Inlet must be attached to the metal collar using screws (not included) through plastic patches on the Inlet Belt. The screw fasteners are particularly important when your inlet is oval or rectangular, but they should always be used. Be sure to locate the zipper start and seam at the 12:00 orientation for proper alignment.



Twist and snap the Glider attachments of the DuctSox onto the cable (pliers may be helpful for

installation and removal of Gliders). Unzip fittings and slide them in place independently of the straight sections. Cable Stops are installed at the Endcap Glider, at the Inlet Glider, and at each Glider immediately adjacent to all fittings. Leave them installed loose until Step 5 is complete. Close all zipper connections before moving to Step 5.

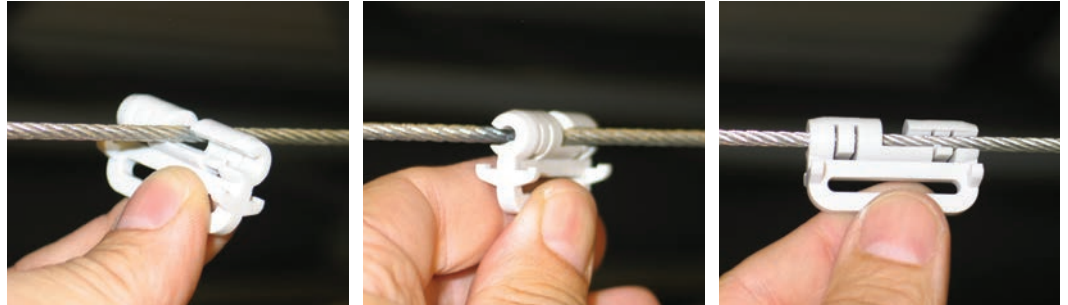

Connect hanger rods to the OvalSox. See illustration below. Connection of hanger rods to the OvalSox may be done prior to locking Glider attachments onto the cable, if desired.

First slide the rod into the rope loops.



Then attach the rod clips to the rod and the webbing.



The Cable Stop is used to keep sections of DuctSox from moving lengthwise on the cable. They also are used to put a slight tension on straight sections of DuctSox (straight sections may consist of more than one zippered section of DuctSox). Nuts are tightened to lock the stop at locations where Gliders are to be locked in place (see Step 5).

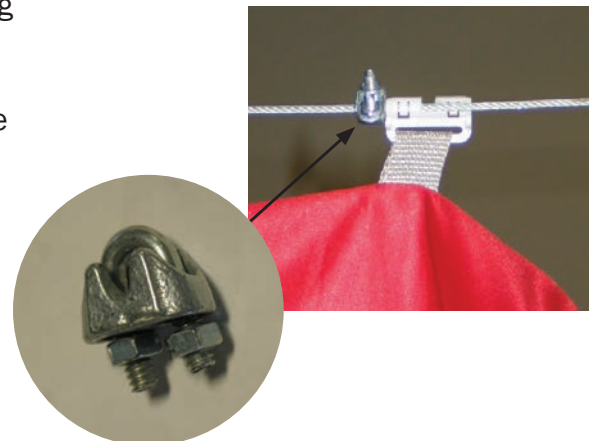

Step 5

Start Up AHU. Turn on the AHU and inflate the DuctSox System. Check all Gliders and sections to ensure system is inflating properly. If required, move Gliders to eliminate puckering at binding locations. If lengths do not fit properly, double check all field measurements and compare to drawings. If all measurements are correct, contact your DuctSox factory rep to discuss options.

Once system is properly adjusted, inflate the system, pull the last Glider in each straight section (including straight sections between fittings), and secure tension using Cable Stops. Also, be sure to install a Cable Stop into the Cable at the Endcap Glider, at the Inlet Glider, and at each Glider immediately adjacent to all fittings.

The Cable Stop is used to keep sections of DuctSox from moving lengthwise on the Cable. They also are used to put a slight tension on straight sections of DuctSox (straight sections may consist of more than one zippered section of DuctSox). The Cable Stop is secured to the Cable at locations where Gliders are to be locked in place.

If the system includes elbows or T's, secure Gliders before and after these fittings. Failure to install DuctSox Systems correctly may void warranty.

Step 6

Air Balancing. System must be balanced to design CFM and static pressure immediately after installation. Most DuctSox Systems include a zipper at the inlet location for easy access to monitor flow.

If the fabric is fluttering after balancing, please contact your factory rep immediately. Solutions to the fluttering include adjusting the Adjustable Flow Device (AFD), adding AFDs, or other solutions that would result in a less turbulent airflow.

Laundering Instructions

- Remove the DuctSox fabric from your system, being sure to unzip all sections. Take care in recording where each section was installed.
- Soak in cold water for 30 minutes.
- Wash cold, gentle cycle.
- Rinse thoroughly (repeat cycle if water/DuctSox still soiled).
- Drip dry or no-heat tumble dry.



If any questions arise regarding the installation of your OvalSox Cable System, contact us.

866-382-8769 or 563-588-5300

DUCTSOX[®]
Textile Air Dispersion Products

9866 Kapp Court ■ Peosta, IA 52068
Ph: 866-382-8769 or 563-588-5300 ■ Fax: 563-588-5330
www.ductsox.com