

NOTICE TO USER	2
SAFETY	2
COMPONENTS	3
INSTALLATION	
Preparation – Required Tools	4
Preparation – Installation Overview	4
Preparation – Inventory	4
Preparation – Panels and Label Tags	5
Preparation – Drawings (Supplied)	6
Preparation – Drawings (Manual)	7
Assemble Rings – Standard	8
Assemble Rings – Inclined	9
Prepare Metal Inlet/Attach Fabric Inlet	10
Hang Rings	11
Attach Straight Tubes	13
Attach Angle Couplers	13
Tension Tubes	14
Attach Fabric to Rings	15
Install Fabric – Standard Straight Sections	16
Install Fabric – Standard End Sections	20
Fittings – Elbows	22
Fittings – Tees/Crosses	24
Fittings – Reducers	28
Fittings – Endcaps	30
Start-Up/Commissioning	31
MAINTENANCE	
Panel Replacement	31
Cleaning	31

NOTICE TO USER

Thank you for purchasing a DuctSox product.

The SkeleCore ETS™ (External Tensioning System) uses an external framework system to bring the DuctSox fabric into complete tension.

Examine materials in box(es). Read and understand all instructions before beginning the installation. Failure to install the DuctSox product correctly may void warranty.

Products may be covered by one or more patents:
www.ductsox.com/patents

Manufactured by DuctSox® Corporation.

SAFETY



DANGER

Risk of fall. DuctSox system not intended to support body weight.



WARNING

Cancer and Reproductive Harm
www.P65Warnings.ca.gov



CAUTION

Barricade the work area during installation or maintenance.

COMPONENTS

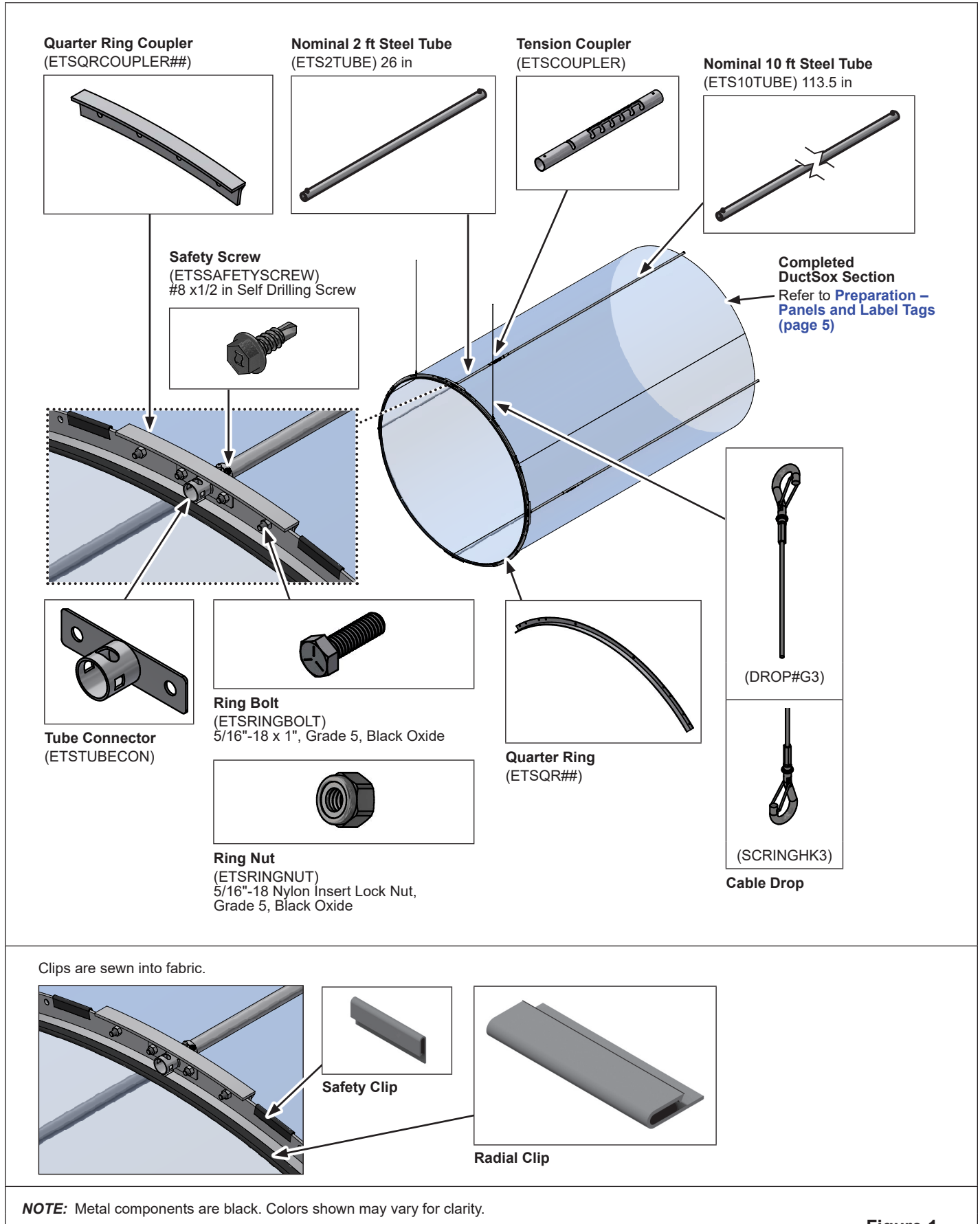

Figure 1

INSTALLATION

Preparation – Required Tools

Drill/Driver and Magnetic #2 Phillips Driver Bit
1/4 in Driver Bit (Safety Screws)
7/16 in Socket or Driver Bit (Angle Coupler)
Level
Tape Measure
Marker or Pencil
1/2 in Socket and Socket Wrench (or Impact and Driver Bit)
1/2 in Wrench
Cable Cutter
1/4 in Drift Punch (Optional)

Preparation – Installation Overview

ETS is installed in sections (rings and fabric).

1. Complete inventory and review all instructions.
2. Assemble rings.
3. Prepare metal inlet and install fabric inlet connection.
4. Identify the next section's hanger location and hang ring.
5. Install the next fabric section.
 - Install tubes.
 - Tension tubes.
6. Repeat steps for all sections.

Preparation – Inventory

Shipping/Receiving

The DuctSox suspension system can be delivered to the job site ahead of the DuctSox fabric sections.

Compare what was received to the BOM. Make sure all boxes are accounted for.

Unpacking

Empty the box(es), examine contents, and make sure all pieces are accounted for. Note any missing or damaged pieces listed on the BOM.

Labeling

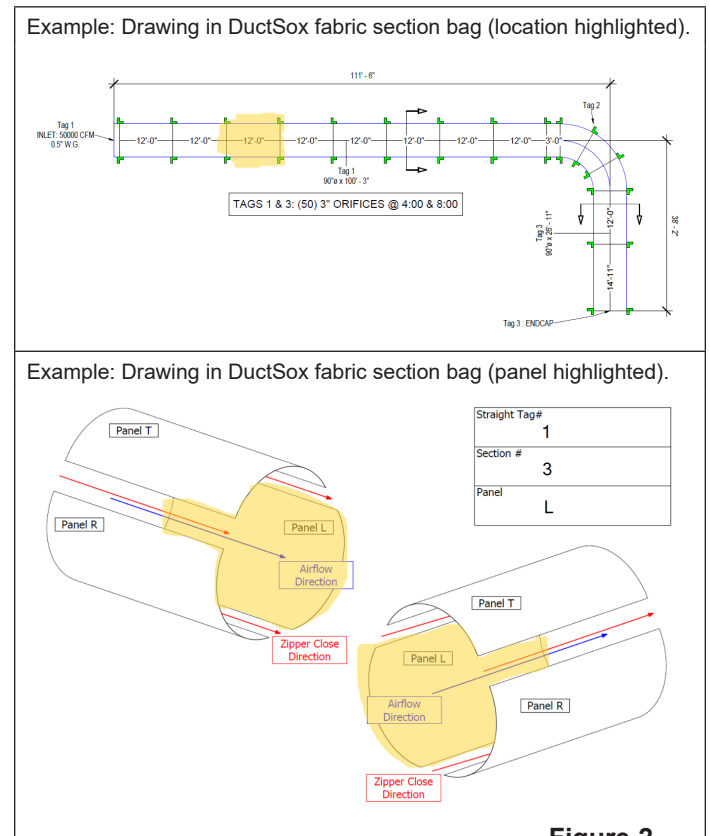

Figure 2

Each DuctSox fabric section should be packaged in a plastic bag labeled with tag number, section number, and panel type. Complex systems may use other markings or labeling.

Each DuctSox section will be marked with the size and section number inside the belt of the inlet or on a tag inside the DuctSox (near the zipper). The marking includes the diameter, section length, tag number, section number, and panel type. If custom labeling has been used, locate an identification sheet that will be included with the delivery.

Refer to [Preparation – Panels and Label Tags \(page 5\)](#).

INSTALLATION

Preparation – Panels and Label Tags

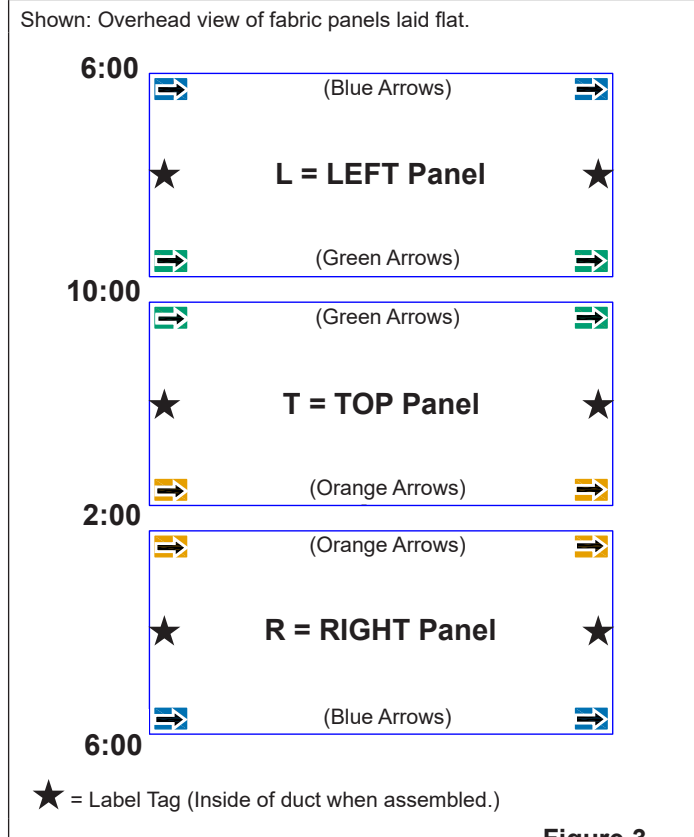
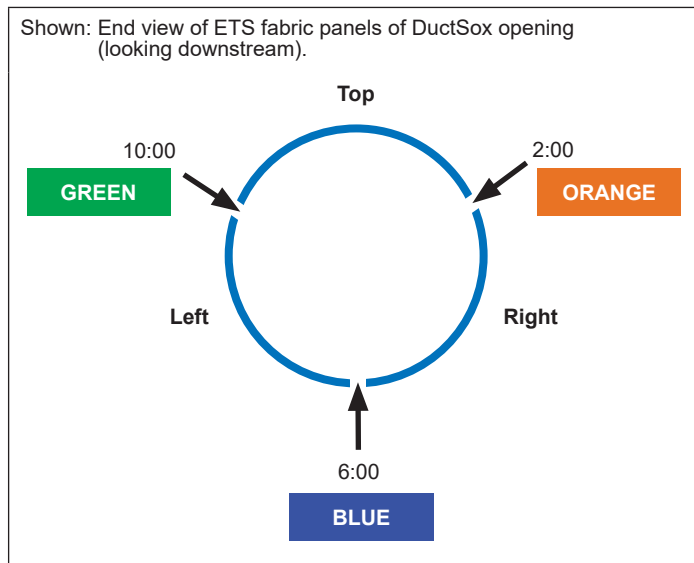
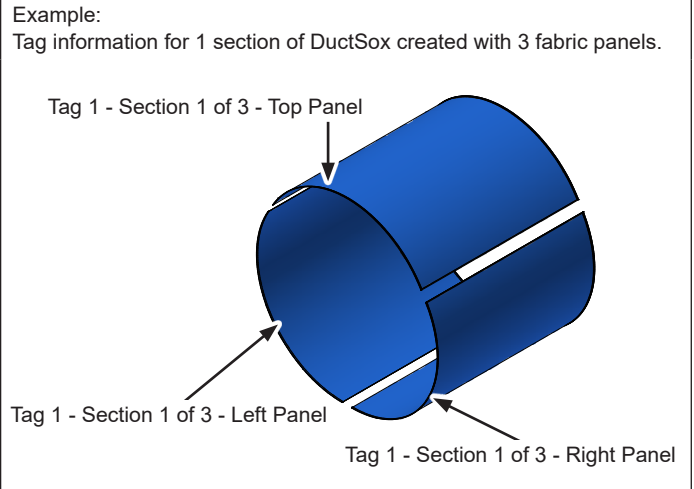

Figure 3



Example: Label tag for right panel.

Job#: 4505375	Date: 5/6/2026
Fabric: Sedona-Xm™	Origin: Made In USA / Processed in Mexico
Diameter: 90" Ø Length: 100' 3"	Label: Tag 1 - Section 3 of 9 - Right Panel
Maintenance: Soak in cold water for 30 minutes. Machine wash cold (85°F), gentle cycle, use mild detergent, no bleach, rinse thoroughly and drip dry.	
	Air Distribution Device in accordance with the flammability requirements of NFPA 90A, 10KM. Classified in accordance with UL Standard 2518
	DANGER: Risk of fall. DuctSox system not intended to support body weight.
DuctSox Corp., 4343 Chavenelle Rd., Dubuque, IA 52002 -- Toll Free: 1-866-3828769	

Figure 4

Each section of DuctSox is created with 3 fabric panels connected by zippers.

- Instructions refer to the pattern of a clock face to describe orientation for installation or assembly. The panels are split at 2:00, 6:00, and 10:00.
- There will be 6 label tags, one in the middle of each end of the panel on the inside of the duct.
- The panels are labeled in the drawings as:
 - L (left) panel
 - T (top) panel
 - R (right) panel
- Zippers will zip in the same direction as the arrow direction on the labels and airflow direction.

INSTALLATION

Preparation – Drawings (Supplied)

Example: Drawing (supplied).

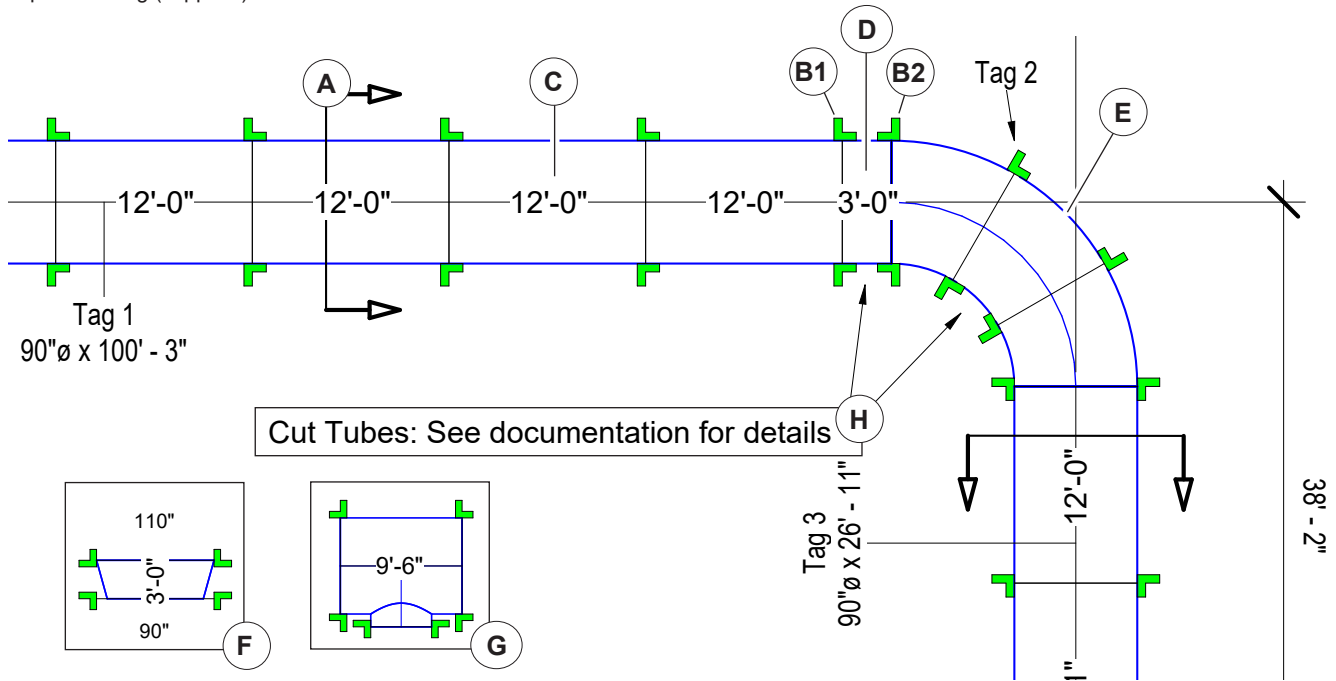

(A) Airflow Direction

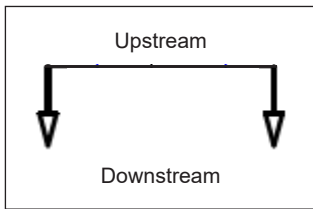

(B) Ring Orientation: Refer to drawing (supplied) to align ring direction with B1, B2.

SYMBOL		
SIDE VIEW OF RING		

(C) Standard Section Length (12 ft 0 in)

(D) End Section Length

NOTE: The last section before a fitting will be a custom length and may have a ring oriented opposite the airflow (B2).

(E) Elbow

(F) Reducer Detail

(G) Tee Detail

(H) Cut Tubes

Figure 5

INSTALLATION

Preparation – Drawings (Supplied) *continued*

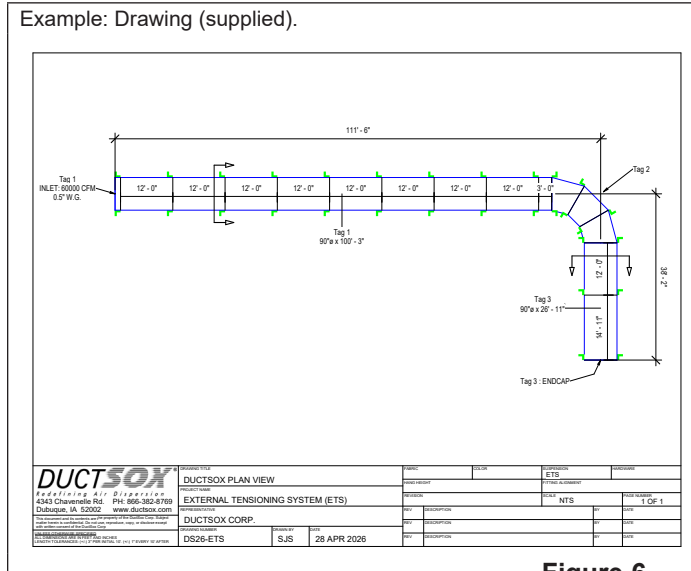

Figure 6

The drawings (supplied) show where the ETS must be hung for the DuctSox system to be installed correctly.

Preparation – Drawings (Manual)

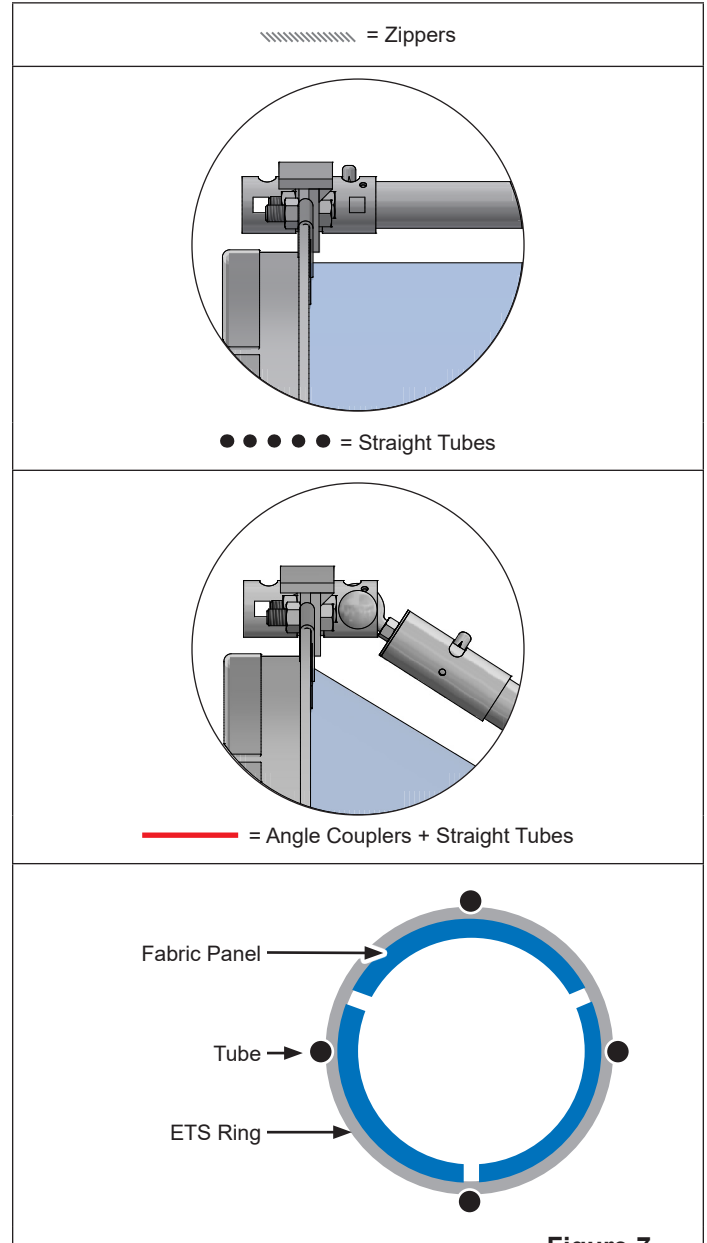

Figure 7

This legend shows components for drawings in the manual.

INSTALLATION

Assemble Rings – Standard

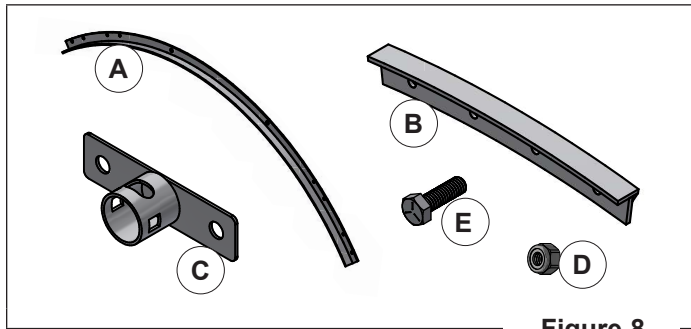

Figure 8

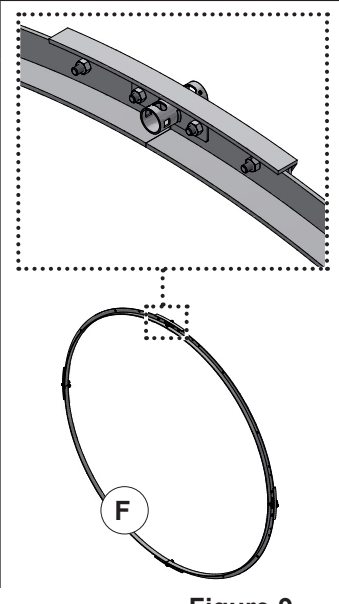
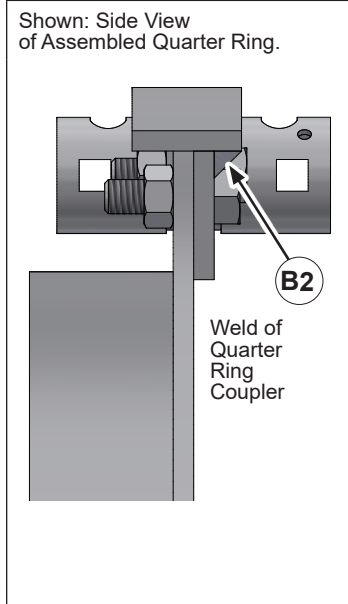
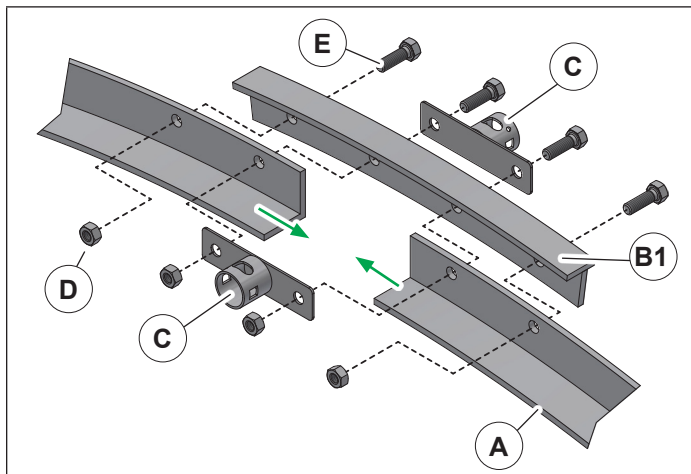

Figure 9

NOTE: Assemble rings at ground level.

1. Locate required parts (Figure 8).

	QTY	DESCRIPTION
(A)	4	Quarter Rings (ETSQR##)
(B)	4	Quarter Ring Couplers (ETSQRCOUPLER##)
(C)	8	Tube Connectors (ETSTUBECON)
(D)	16	Ring Nuts (ETSRINGNUT)
(E)	16	Ring Bolts (ETSRINGBOLT)

2. Align holes of 2 quarter rings (A) with holes of 1 quarter ring coupler (B1).

Make sure quarter ring coupler is positioned on the ring side opposite the horizontal flange with the welded section (B2) to the non-flange side.

3. Align 2 tube connectors (C) with center holes.

Make sure the opening of the tube connector is pointed away from the vertical ring flange to make tube installation easier.

4. Attach with 4 ring nuts (D) and ring bolts (E).

Use a drift punch as necessary to align the holes and attach the bolts.

5. Repeat steps until ring (F) is completed.

INSTALLATION

Assemble Rings – Inclined

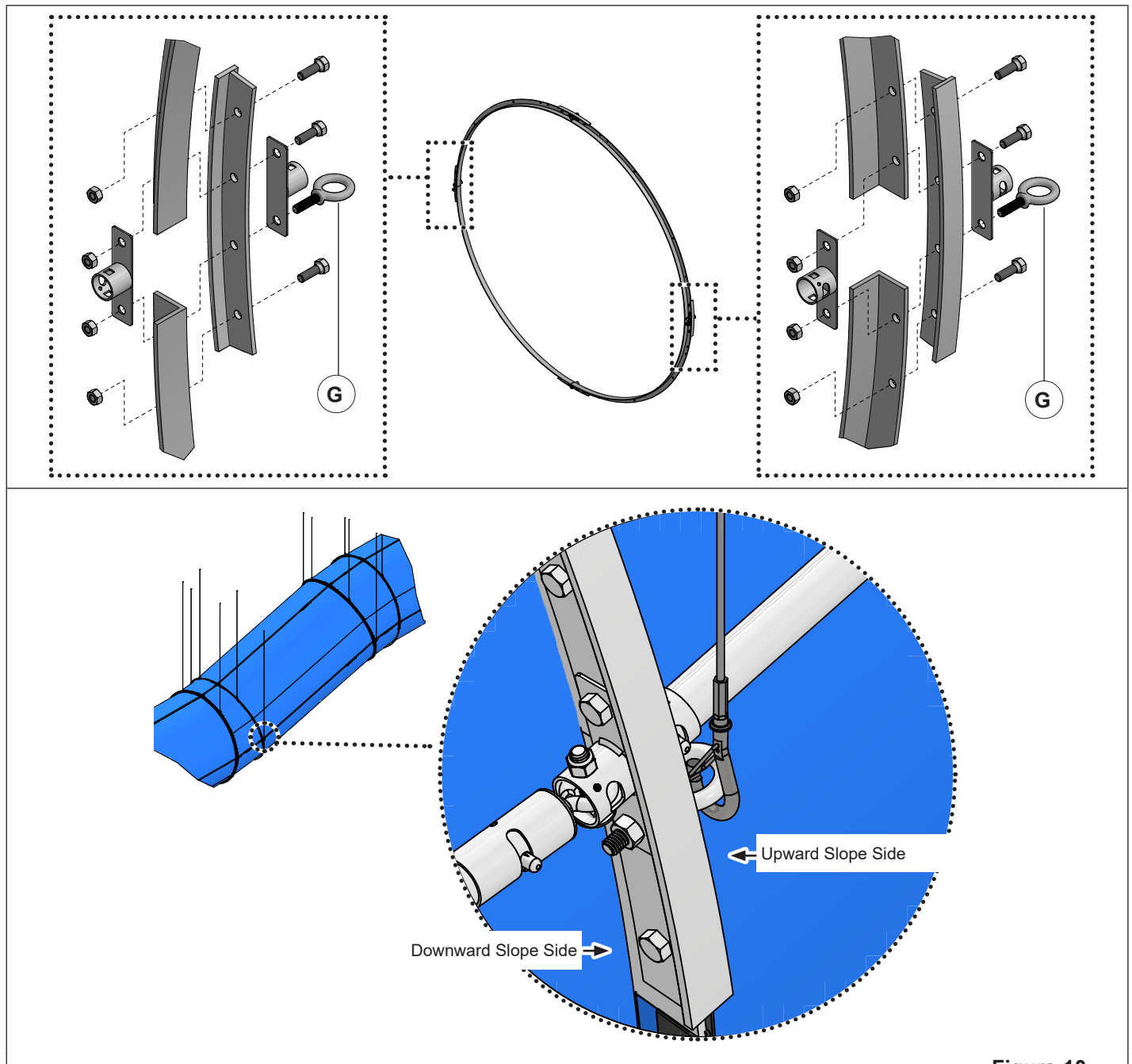

Figure 10

Inclined rings are used on any section that changes elevation.

Assemble inclined rings the same as a standard ETS rings except for one piece of hardware. Refer to "[Assemble Rings – Standard \(page 8\)](#)".

- Assemble rings at ground level.
- Replace the bolt directly below the 3:00 and 9:00 tube connectors with an eyebolt (G).
- The eyebolts must be installed on the upward slope side of the ring.

NOTE: If the eyebolts are installed on the wrong side when the ring is hung, remove and reinstall the eyebolt on the correct side. The ring does not need to be disassembled.

INSTALLATION

Prepare Metal Inlet/Attach Fabric Inlet

1. Locate required parts:

QTY	DESCRIPTION
1	Assembled ETS Ring
1	Fabric Inlet Belt NOTE: Metal screws to install the fabric inlet belt are supplied by others.
1*	Edge Guard (EDGING) *Bulk length (supplied) must be cut to fit circumference of each metal inlet.
2	Cable Drops (DROP#G3 and SCRINGHK3)

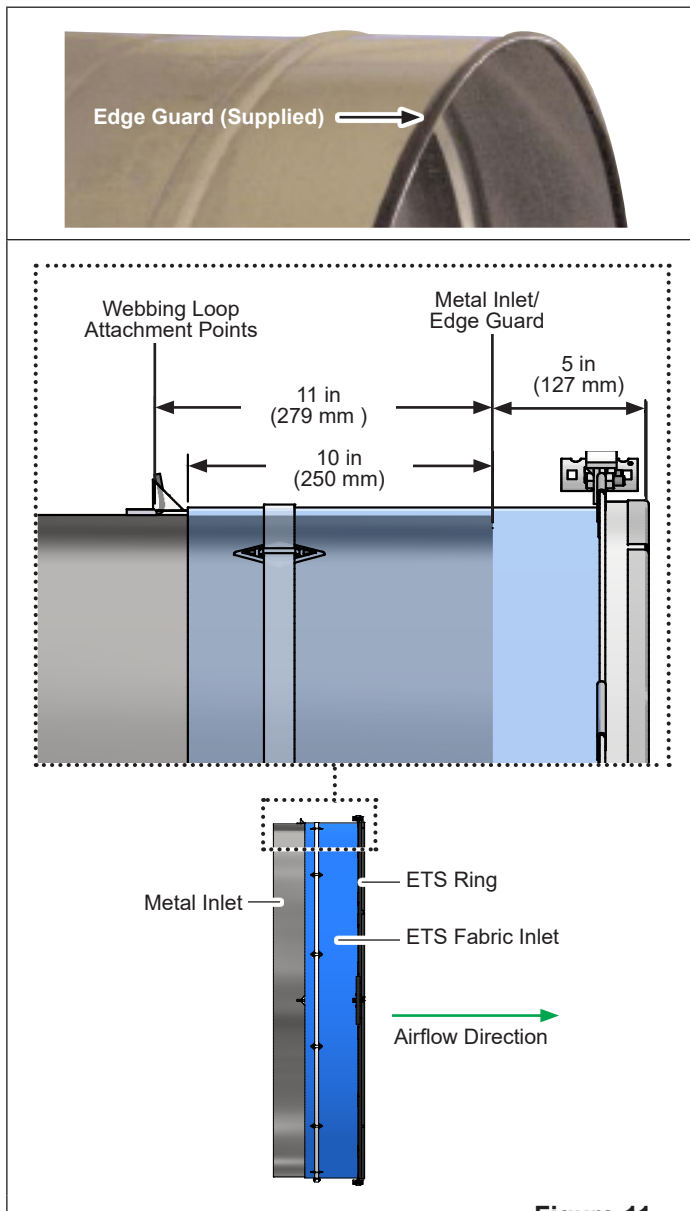

Figure 11

Prepare metal inlet collar for fabric connection:

- Confirm inlet air supply size.
 - DuctSox inlets are manufactured 1/2 in (12 mm) larger than specified to fit over metal inlet collar.
 - Metal inlet collar length should be a minimum of 12 in (305 mm) for secure fabric attachment.
- Install 3 webbing loop attachment points (for example, bolts or welded studs) 11 in (279 mm) from the end of the metal inlet.
 - DuctSox fabric inlets have 3 webbing loops located at 12:00, 3:00, and 9:00.
 - Webbing loop attachment points should be $\approx 1 \frac{1}{2}$ in long.
 - Webbing loop attachment points will temporarily hold the weight of the inlet (≈ 10 lb), but will not hold any weight once the inlet is fully installed.
- Install edge guard (supplied) on the edge of the metal inlet collar to reduce fabric wear from the metal edge.

Attach fabric inlet to metal inlet:

- Refer to **"Hang Rings" (page 11)** to install an ETS ring facing downstream 5 in (127 mm) from the metal inlet collar. Refer to drawing (supplied) to determine ring orientation.

NOTE: Ring orientation usually matches airflow direction.
- Slide the fabric inlet belt over the metal inlet collar with the safety clips, radial clips, and zipper on the same side as the ETS ring.
- Hook the webbing loops to the webbing loop attachment points to make sure the fabric is oriented correctly.
- Position the remaining fabric inlet belt onto the metal inlet collar. Keep square. The fabric and metal should have a 10 in (250 mm) overlap.

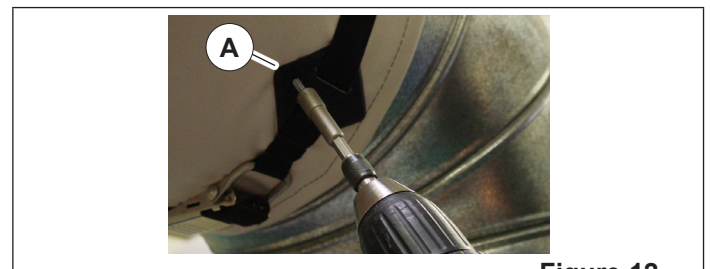

Figure 12

- Tighten the fabric inlet belt. Drill the sheet metal screws through the plastic inlet patches (A) on the inlet belt to secure the fabric to the metal inlet collar.
- Pull the inlet cover over the inlet belt.
- Attach radial clips and safety clips to the ETS ring. Refer to **Attach Fabric to Rings (page 15)**.

INSTALLATION

Hang Rings

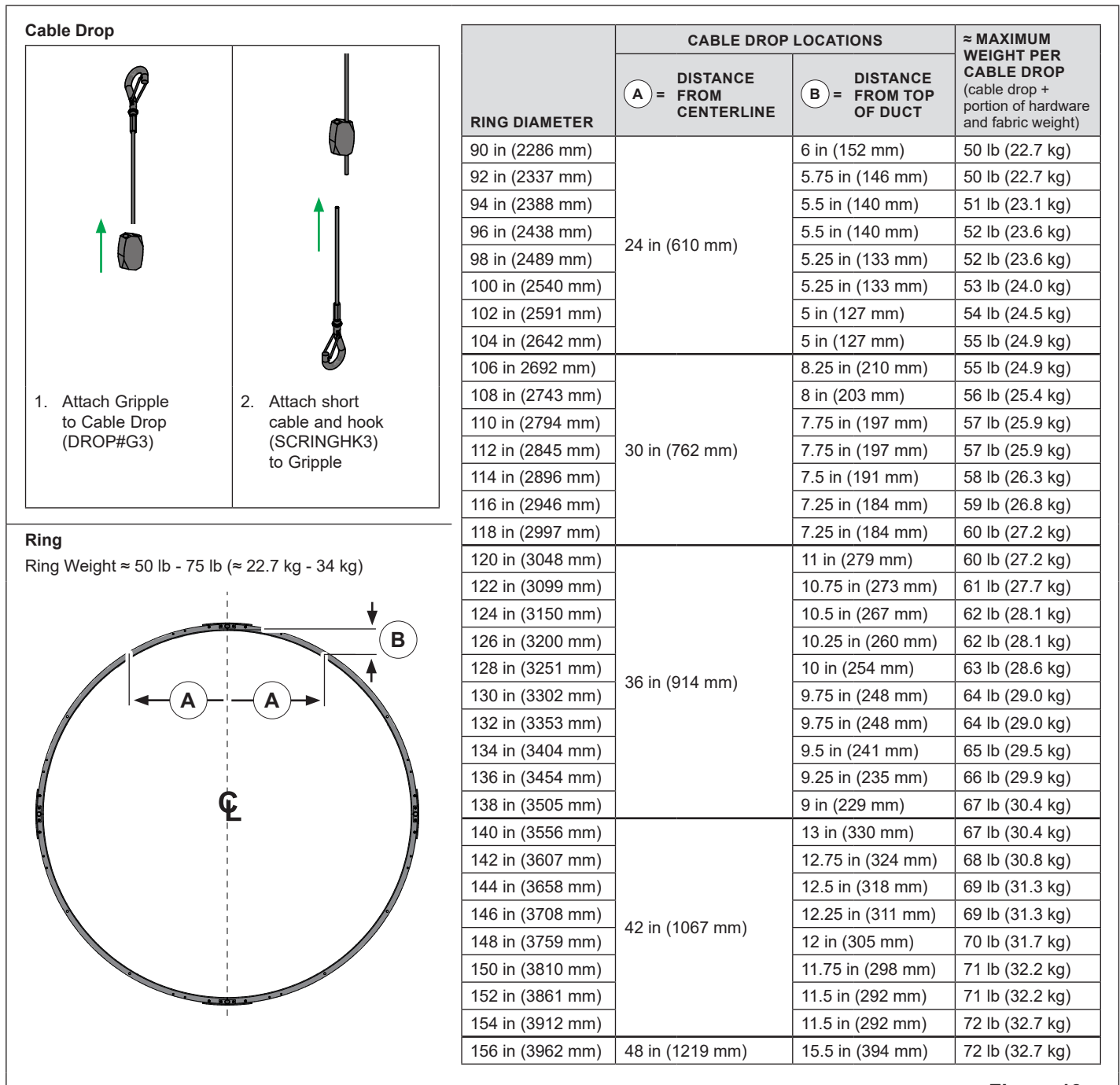

Figure 13

Hang cable drops:

1. Locate required parts (for each ring location):

QTY	DESCRIPTION
2	Cable Drops (Drop#G and SCRINGHK3)

2. Refer to the drawing (supplied) to determine the diameter of rings and distance between ring locations.
3. Determine how far to hang each cable drop from the centerline (A) (Figure 13).

4. Use the site-specific top-of-duct requirements to set your cable length. Refer to (B) (Figure 13) for recommended distances.
5. Attach cable drops (long cables) to the building structure.
6. Use the gripple (supplied) to attach the ring hooks (short cables) to the cable drops.

NOTE: If the hanging locations don't work for the application, contact your DuctSox representative for alternate hanging locations.

INSTALLATION

Hang Rings *Continued*

Standard Rings

1. Locate required parts:

QTY	DESCRIPTION
1	Assembled ETS Ring

2. Hang the standard ETS Ring.

- a. Refer to the drawing (supplied) to determine the ring orientation. Refer to **"Preparation – Drawings (Supplied)"** (page 7).
- b. Hang the ETS ring by attaching it to the cable drops. Use the hook ends to attach to the holes on the rings.

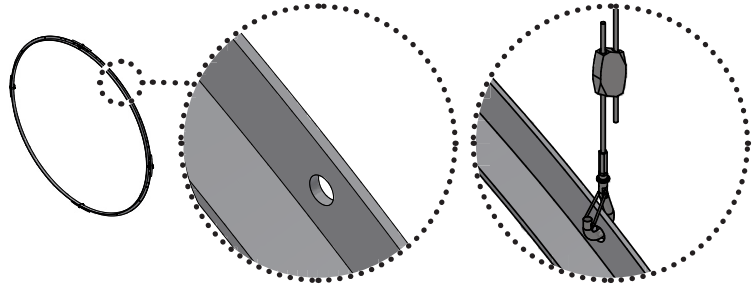

Inclined Rings

1. Locate required parts:

QTY	DESCRIPTION
1	Assembled Inclined ETS Ring

2. Hang the inclined ETS ring:

- a. Refer to the drawing (supplied) to determine the ring orientation. Refer to **"Preparation – Drawings (Supplied)"** (page 7).
- b. Hang the inclined ETS ring by attaching it to the cable drops. Use the hook ends to attach to the holes on the rings. Refer to **"Hang Rings"** (page 11).
- c. Hang additional support cables for the eyebolts. Attach these cables to the eyebolts. Refer to **Assemble Rings – Inclined** (page 9).
Tighten additional support cables to raise ring into inclined position.

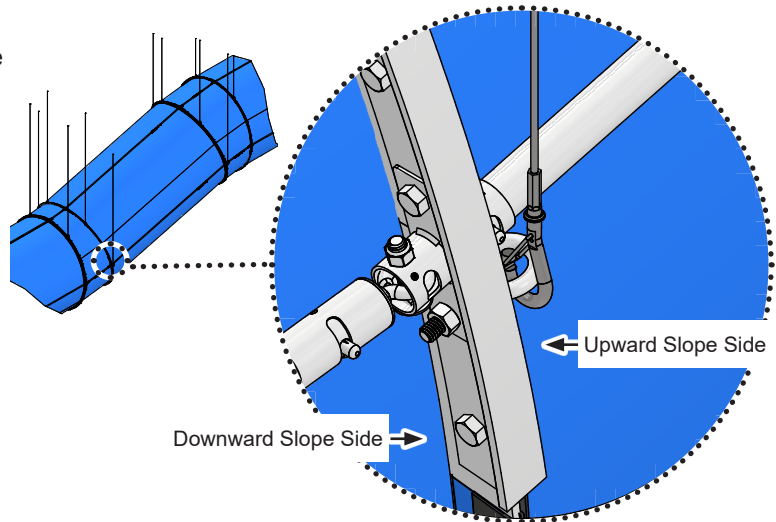

Seismic Bracing (Supplied by Others)

SkeleCore ETS is compatible with seismic bracing. Holes ([2] 1/2 in) are supplied to attach suspension/bracing.

Refer to **"Hang Rings"** (page 11) to determine the hanging locations for (A) and (B).

NOTE: If the hanging locations don't work for the application, contact your DuctSox representative for alternate hanging locations.

INSTALLATION

Attach Straight Tubes

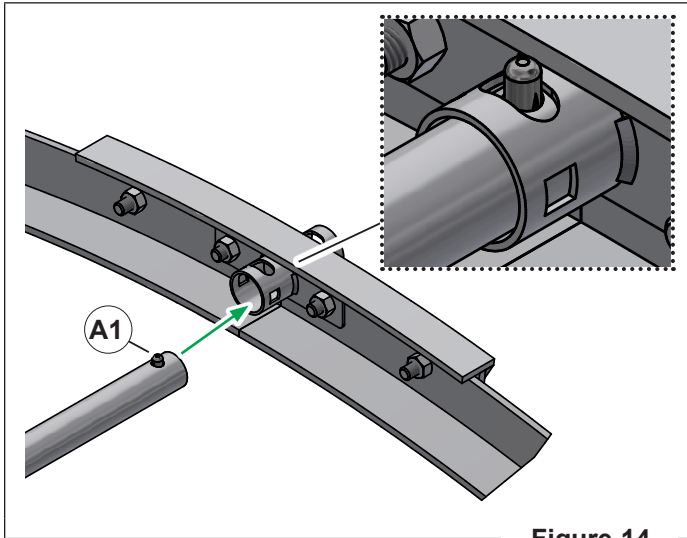

Figure 14

Push the pin (A1) down on the end of the tube and insert tube into the tube connector on the ring. The pin will release in the tube connector to complete the connection.

Attach Angle Couplers

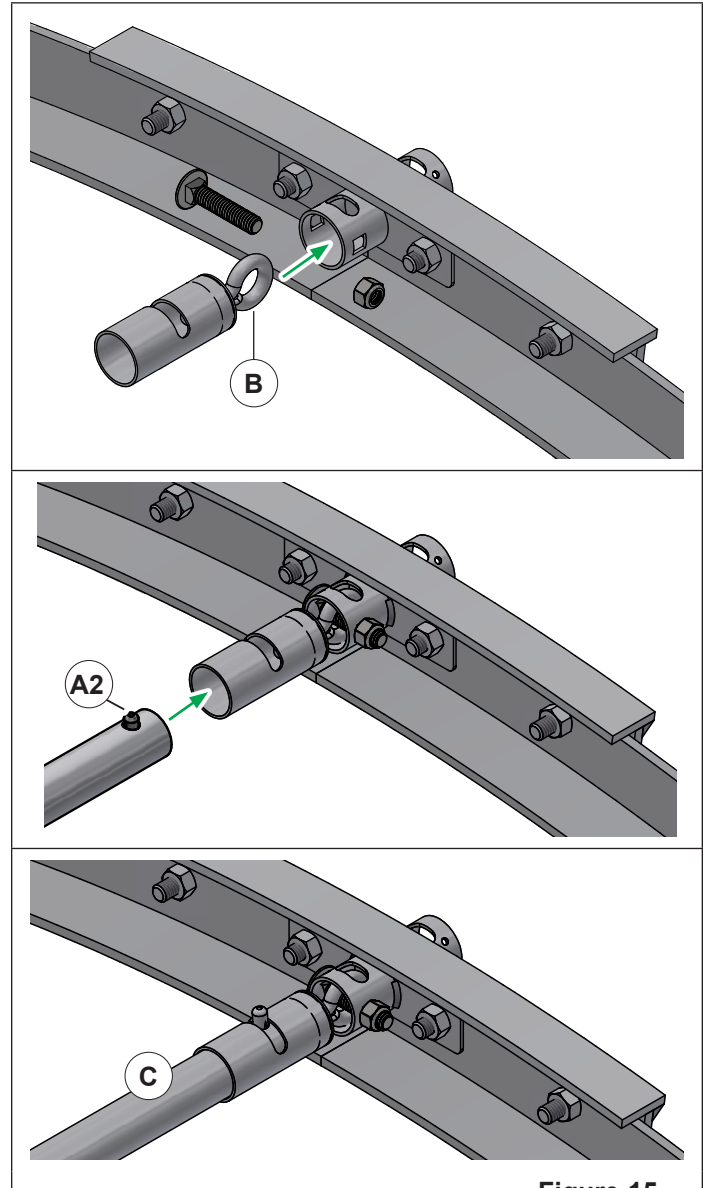

Figure 15

NOTE: Angle couplers are used when a DuctSox section changes direction or elevation.

1. Put the eye (B) of the angle coupler eyebolt into the tube connector on the ring. Secure with a nut and bolt (supplied).
2. Push the pin (A2) down on the end of the tube and insert tube (C) into angle coupler. The pin will release in the angle coupler to complete the connection.

INSTALLATION

Tension Tubes

CAUTION



Pinch hazard:

Keep hands away from slots on the tension coupler while adjusting tension.

Each 12 ft straight section is made up of (1) 10 ft tube and (1) 2 ft tube connected by a tension coupler.

Sections that are not 12 ft will have different length tubes/cut tubes (ETSCUTTUBE).

NOTE: The pin position in the tension coupler will vary from what is shown.

The pin position is dependent on the tube length and tensioning required.

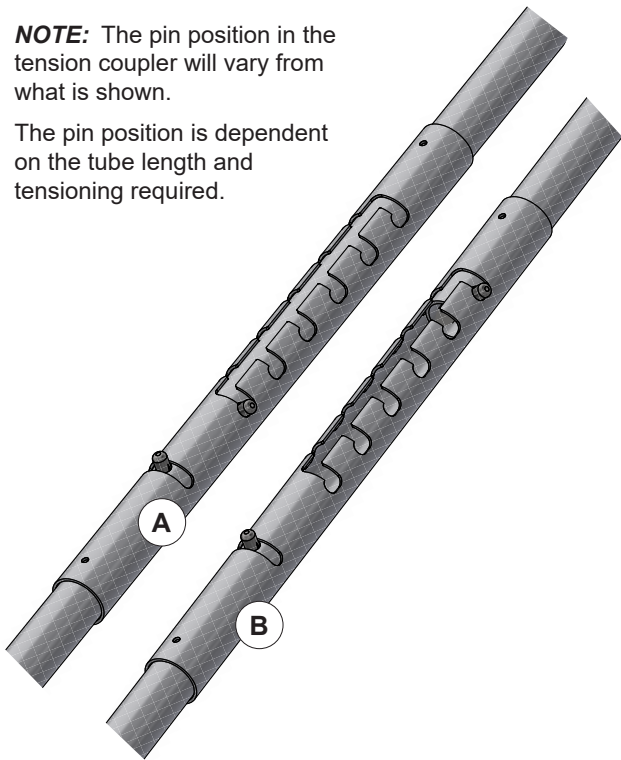
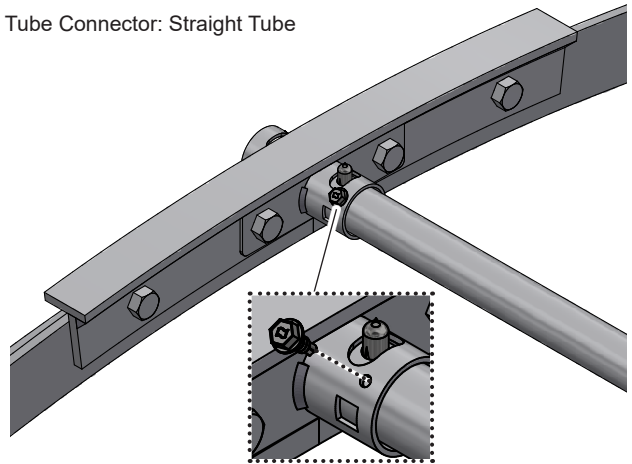

Figure 16

1. When installing the tube, leave the tension coupler in the untensioned position (A) until fabric and all tubes are installed.
2. Set the necessary tension (B). Twist and pull the tubes. The fabric will appear tight when tensioned.

NOTE: The tension coupler does not need to be fully extended for section to be tensioned correctly.

Tube Connector: Straight Tube



Tube Connector: Angle Coupler

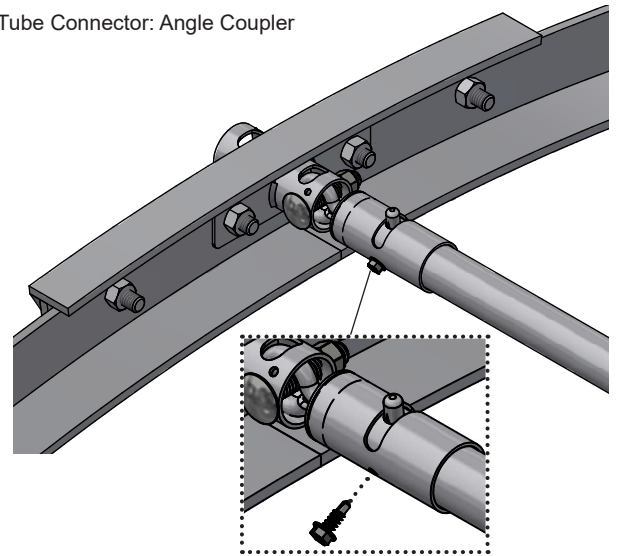

Tension Coupler

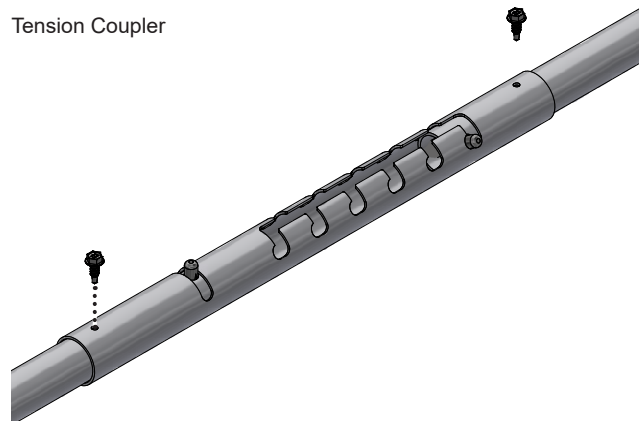

Figure 17

3. Install safety screws in the tube connectors (angle couplers, straight) and tension couplers.

INSTALLATION

Attach Fabric to Rings

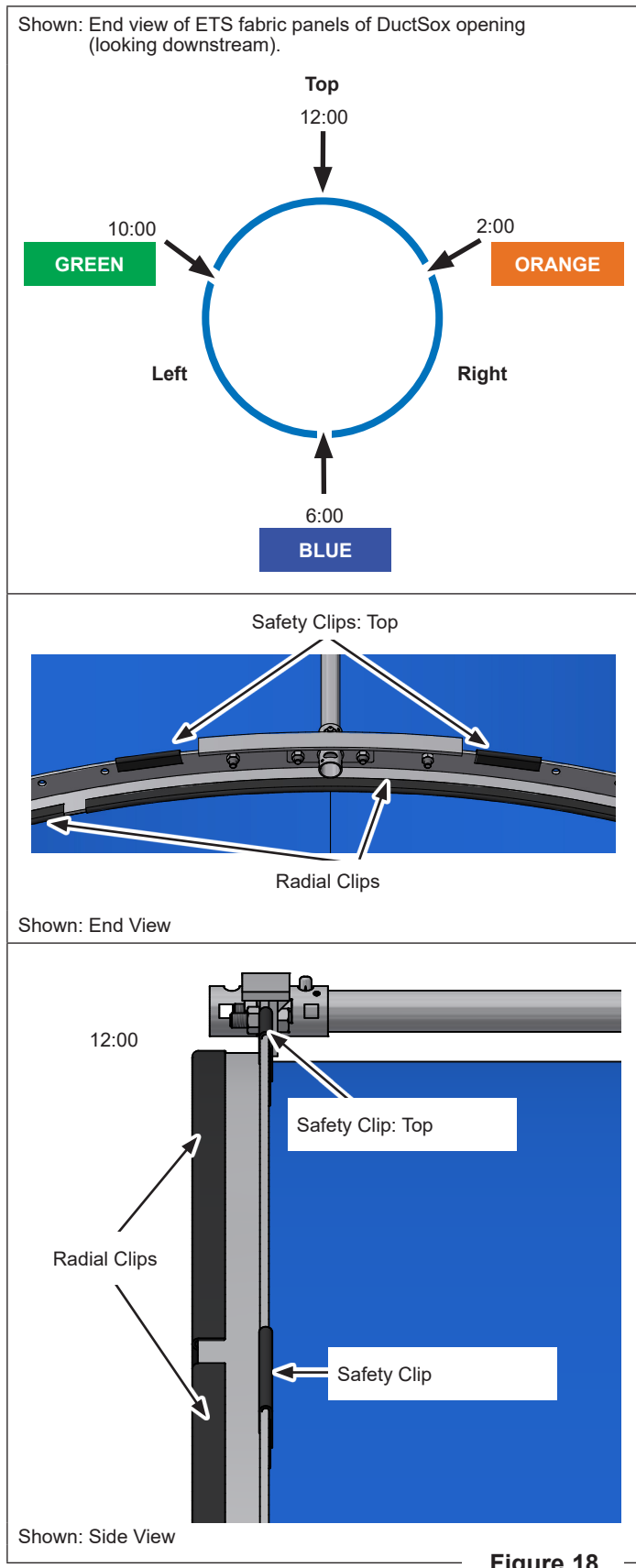

Figure 18

1. Locate the label tag at 12:00 on the top panel.
2. Install the 2 safety clips on either side of the 12:00 label on the vertical ring flange, with 1 safety clip on each side of the top quarter ring coupler.

NOTE: Standard fabric panels have the safety clips and radial clips sewn in.
3. Begin installing the radial clips on the horizontal flange. While installing the radial clips, continue installing the safety clips.

INSTALLATION

Install Fabric – Standard Straight Sections

1. Locate required parts:

QTY	DESCRIPTION
1	Assembled ETS Ring
4	10 ft Tubes (ETS10TUBE)
4	2 ft Tubes (ETS2TUBE)
4	Tension Couplers (ETSCOUPLER)
3	Fabric Panels
2	Cable Drops (Drop#G and SCRINGHK3)
16	Safety Screws (ETSSAFETYSCREW)

Example: End view of completed section (looking downstream).

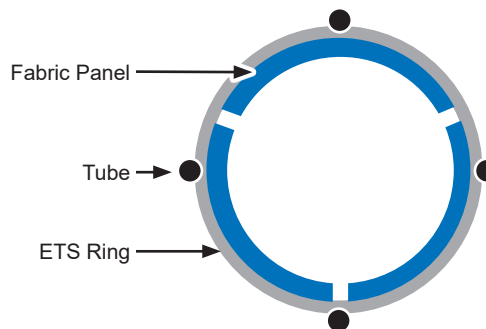

2. Hang the ring downstream with the flange (A) facing downstream.

NOTE: Previous section must already be installed.

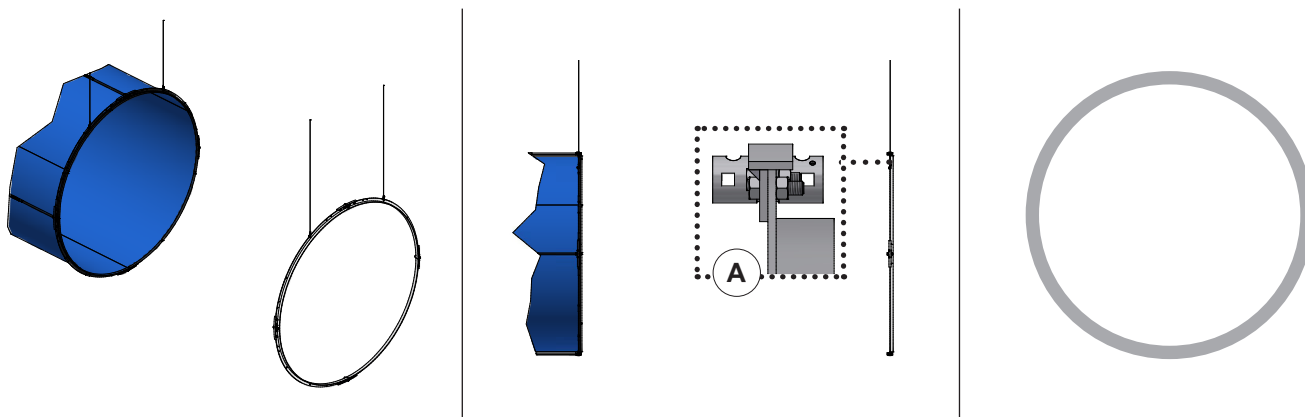

3. Install the 12:00 tubes. Refer to [Attach Straight Tubes \(page 13\)](#). Measure between vertical flanges to set tube length as close to designated section length as possible. Refer to drawing (supplied). Install safety screws.

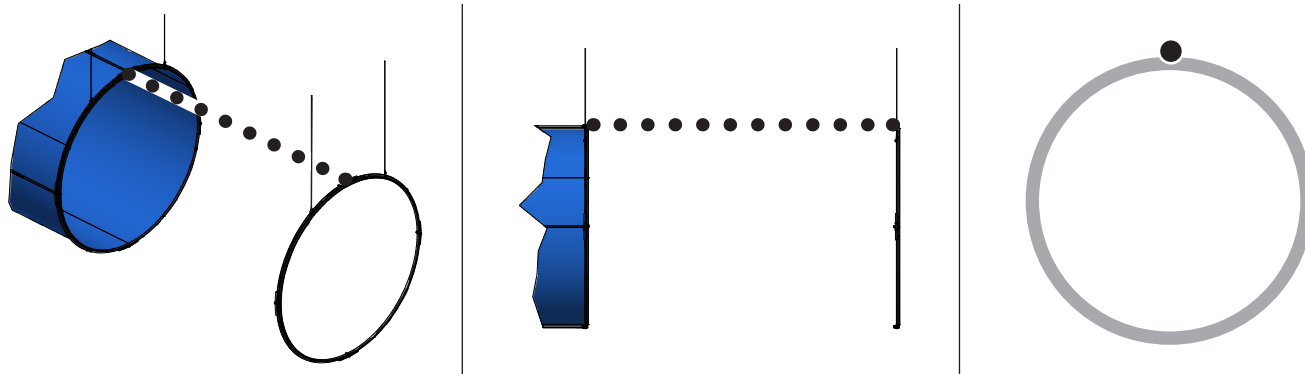

INSTALLATION

Install Fabric – Standard Straight Sections *Continued*

4. Install the top panel onto the downstream ring with the radial clips and safety clips. Refer to **Attach Fabric to Rings (page 15)**.
5. Zip this panel to the upstream fabric section.

The diagram for step 5 illustrates the installation of the top panel. On the left, a close-up shows 'Safety Clips' and 'Radial Clips' being used to secure the fabric to a ring. Below this is a 3D perspective of a duct section with a blue fabric panel being attached to the top. In the center, a flat rectangular panel is shown with '10:00 (Green Arrows)' at the top and '2:00 (Orange Arrows)' at the bottom. Below the panel is a side view showing the fabric being zipped to the upstream section. On the right, a circular ring diagram shows a blue segment at the top, with a black dot indicating a reference point.

6. Zip left panel to the top panel.
7. Install the fabric onto the downstream ring with the radial clips and safety clips.
8. Zip this panel to the upstream fabric section.

The diagram for step 8 illustrates the installation of the left panel. On the left, a 3D perspective shows a duct section with a blue fabric panel being attached to the left side. In the center, a flat rectangular panel is shown with '6:00 (Blue Arrows)' at the top and '10:00 (Green Arrows)' at the bottom. Below the panel is a side view showing the fabric being zipped to the upstream section. On the right, a circular ring diagram shows a blue segment on the left, with a black dot indicating a reference point.

INSTALLATION

Install Fabric – Standard Straight Sections *Continued*

9. Zip right panel to the top panel.
10. Install the fabric onto the downstream rings with the radial clips and safety clips.
11. Zip this panel to the upstream fabric section
12. Zip the left and right panels together at 6:00.

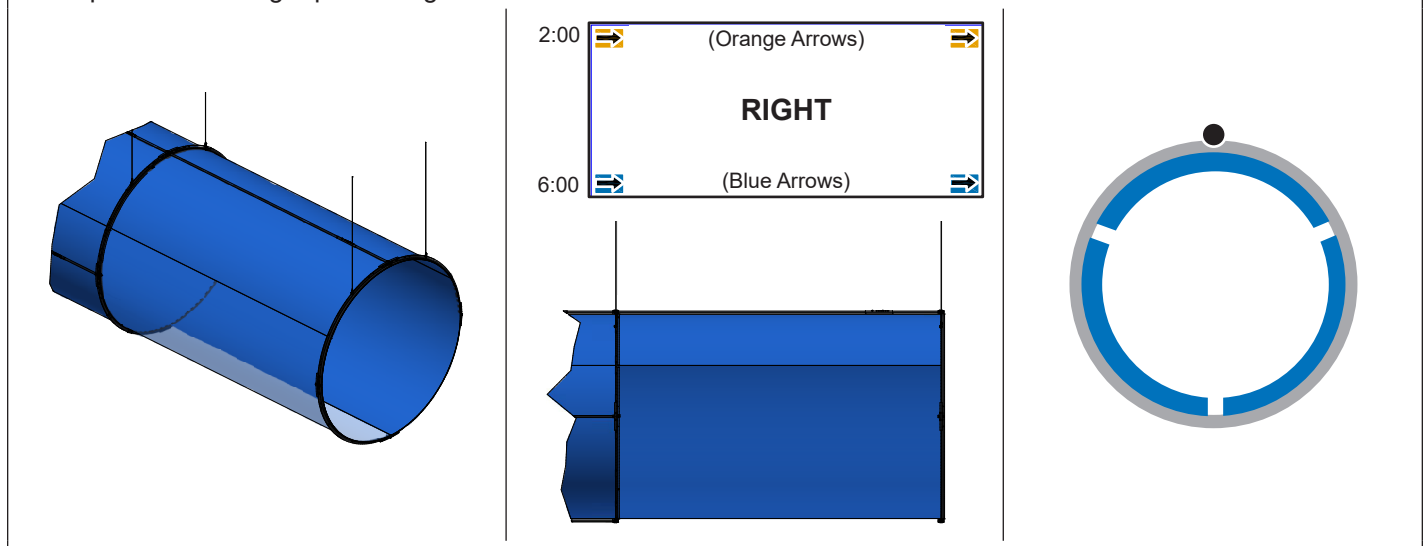

13. Install remaining tubes onto the rings. Tension fabric with the tension coupler to specified length in drawing (supplied). Install safety screws. Refer to [Tension Tubes \(page 14\)](#).
14. Make sure all zippers are zipped closed, all clips are attached to the ring, all covers are folded over zippers, and all safety screws are installed.

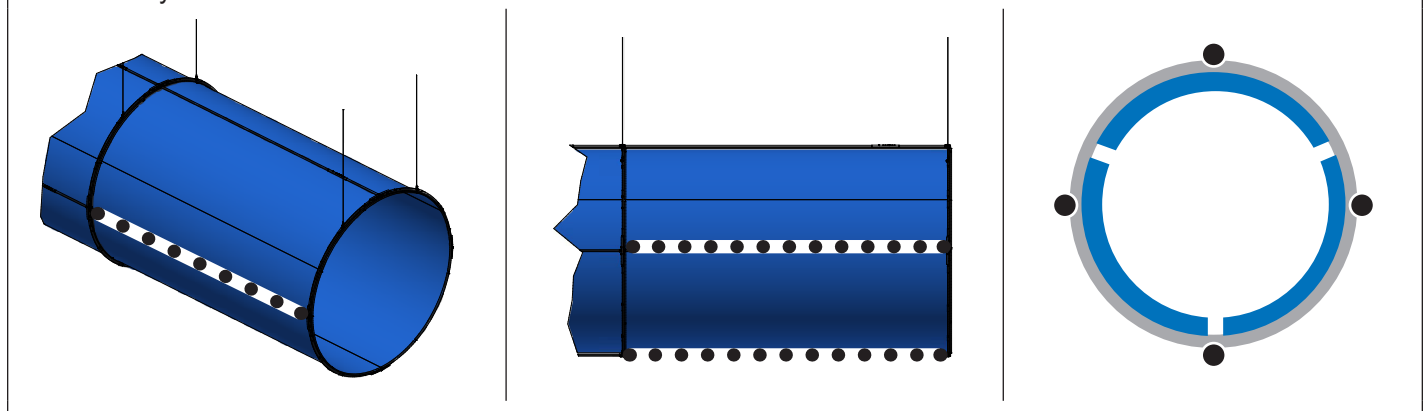

INSTALLATION

Install Fabric – Standard End Sections

1. Locate required parts:

QTY	DESCRIPTION
Refer to supplied documents for tubes and lengths: (4) 2 ft Tubes (ETS2TUBE) + (4) End Tubes (ETSCUTTUBE) or (4) 10 ft Tubes (ETS10TUBE) + (4) End Tubes (ETSCUTTUBE)	
4	Tension Couplers (ETSCOUPLER)
3	Fabric Panels
16	Safety Screws (ETSSAFETYSCREW)

Example: End view of completed section (looking downstream).

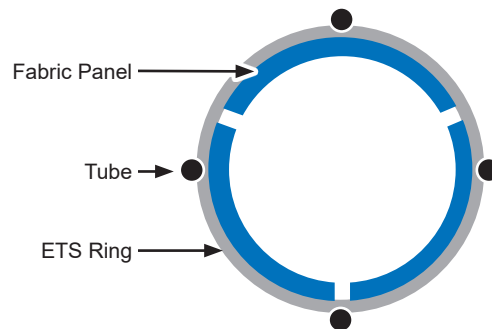

2. Install the downstream section (A) before the end section.

NOTE: Downstream section could be a tee, cross, elbow, transition, or endcap.

3. Install the 12:00 tubes. Refer to [Attach Straight Tubes \(page 13\)](#). Measure between vertical flanges to set tube length as close to designated section length as possible. Refer to drawing (supplied).

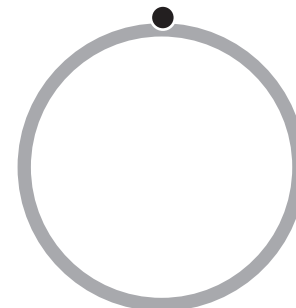
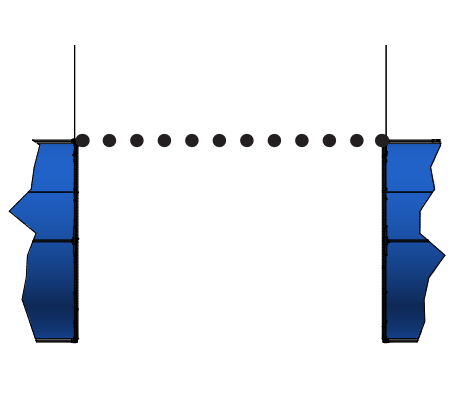
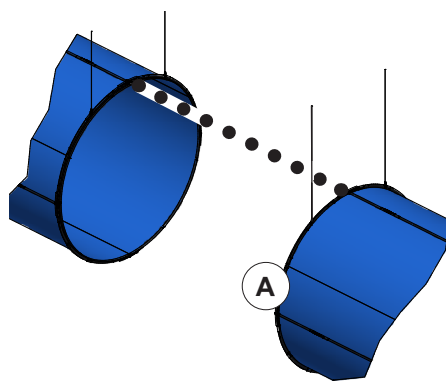

4. Zip the top panel to both the upstream and downstream sections.

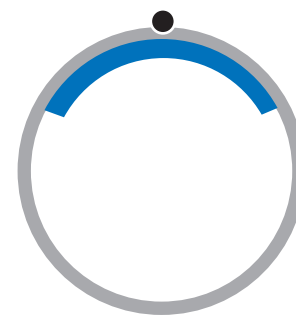
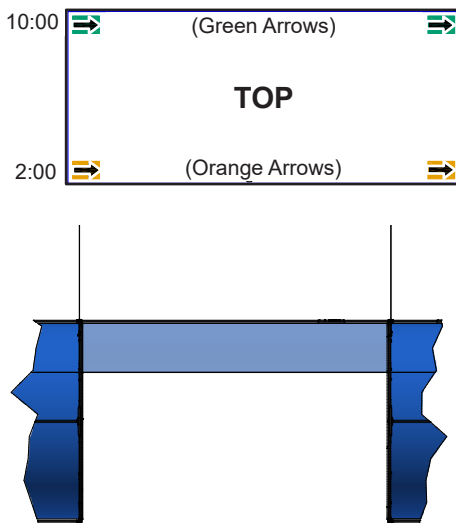
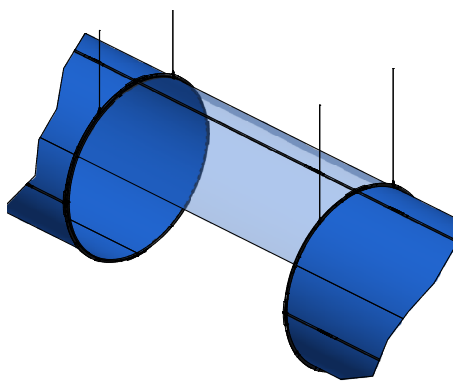

INSTALLATION

Install Fabric Sections – Standard End Sections *Continued*

5. Zip left panel to the top panel.

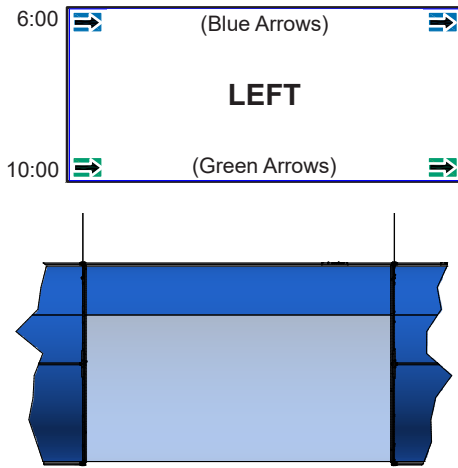
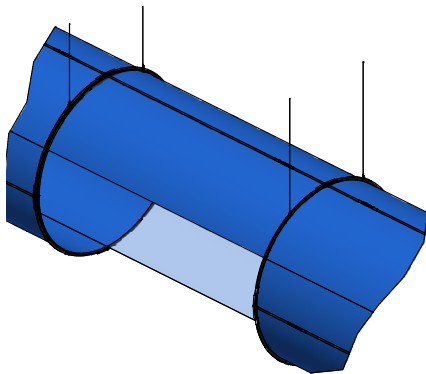

6. Zip right panel to top panel.

7. Zip left and right panels to the upstream and downstream sections.

8. Zip left and right panels together at 6:00.

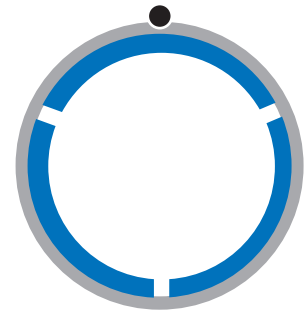
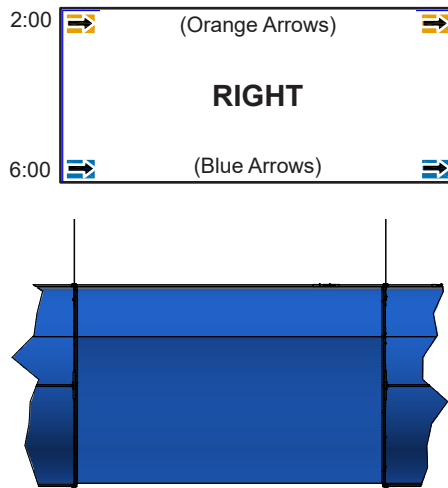
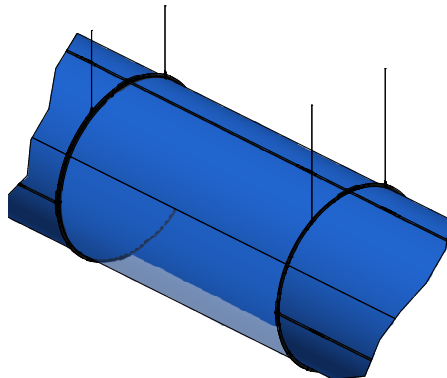

9. Install remaining tubes onto the rings. Tension fabric with the tension coupler to specified length in drawing (supplied). Install safety screws. Refer to **Tension Tubes (page 14)**.

10. Make sure all zippers are zipped closed, all covers are folded over zippers, and all safety screws are installed.

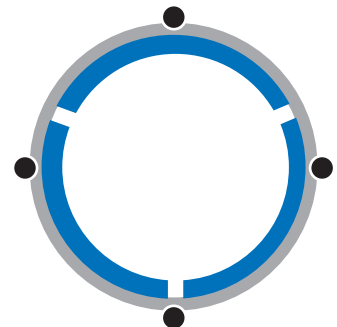
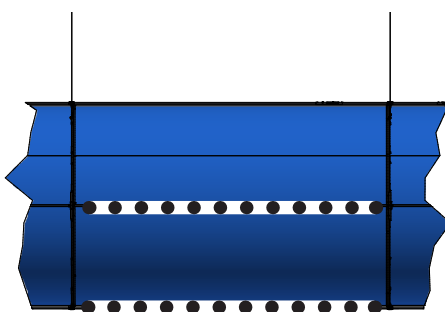
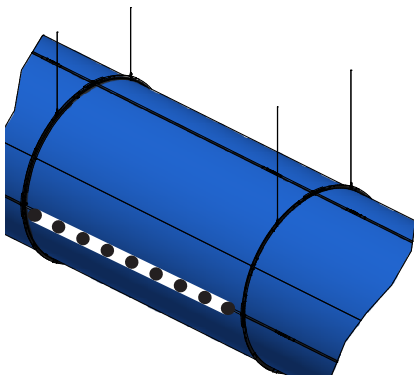

INSTALLATION

Fittings – Elbows

1. Locate required parts:

	1 GORE	2 GORE	3 GORE
Assembled ETS Rings	2	3	4
Elbow Tubes (ETSCUTTUBE) Refer to supplied documents for tube length.	4-8	8-16	12-24
Tension Couplers (ETSCOUPLER)	4	8	12
Angle Couplers (ETSANGLECOUPLER)	8	16	24
Cable Drops (DROP#G3 and SCRINGHK3)	4	6	8
Fabric Panels	3	6	9
Safety Screws (ETSSAFETYSCREW)	16	32	48

2. Determine the number of rings and gores needed for elbow fitting. Refer to the drawings (supplied).

DEGREES	# OF GORES	# OF RINGS
1° – 30°	1	2
31° – 60°	2	3
61° – 90°	3	4

3. Identify elbow tubes. Refer to the drawings (supplied).

Most tube locations will use:

- 2 angle couplers
- 2 elbow tubes
- 1 tension coupler

In some locations, elbows with small gores may use:

- 2 angle couplers
- 1 elbow tube
- 0/No tension couplers

4. Install elbows. Refer to **Figure 19 (page 23)**.

- To install fabric panels on rings, refer to **Attach Fabric to Rings (page 15)**.
- To install tubes and angle couplers, refer to **Attach Angle Couplers (page 13)**.
- To tension sections, refer to **Tension Tubes (page 14)**.

5. Make sure all zippers are zipped closed, all clips are attached to the ring, all covers are folded over zippers, and all safety screws are installed.

INSTALLATION

Fittings – Elbows *Continued*

1 GORE	2 GORE	3 GORE
 <p>Hang both rings.</p>	 <p>Build 1 gore (refer to 1 gore procedure). Hang third ring.</p>	 <p>Build 2 (first and third) 1 gores (refer to 1 gore procedure).</p>
 <p>Install the top tubes.</p>	 <p>Install the top tubes.</p>	 <p>Install the top tubes.</p>
 <p>Install the top, left, and right fabric panels.</p>	 <p>Install the top, left, and right fabric panels. Zip the gores together.</p>	 <p>Install the top, left, and right fabric panels. Zip the gores together.</p>
 <p>Install the remaining tubes and tension.</p>	 <p>Install the remaining tubes and tension.</p>	 <p>Install the remaining tubes and tension.</p>

Figure 19

INSTALLATION

Fittings – Tees/Crosses

	TEE	CROSS																																																
1.	Locate required parts:																																																	
	<table border="1"> <thead> <tr> <th>QTY</th> <th>DESCRIPTION</th> </tr> </thead> <tbody> <tr> <td>3</td> <td>Assembled ETS Rings</td> </tr> <tr> <td>6</td> <td>Trunk Tubes (ETSCUTTUBE) Refer to supplied documents for tube length.</td> </tr> <tr> <td>8</td> <td>Branch Tubes (ETSCUTTUBE) Refer to supplied documents for tube length.</td> </tr> <tr> <td>8</td> <td>Angle Couplers (ETSANGLECOUPLER)</td> </tr> <tr> <td>16</td> <td>Ring Bolts (ETSRINGBOLT)</td> </tr> <tr> <td>16</td> <td>Ring Nuts (ETSRINGNUT)</td> </tr> <tr> <td>7</td> <td>Tension Couplers (ETSCOUPLER)</td> </tr> <tr> <td>8</td> <td>Tube Connectors (ETSTUBECON)</td> </tr> <tr> <td>6</td> <td>Cable Drops (DROP#G3 and SCRINGHK3)</td> </tr> <tr> <td>4</td> <td>Fabric Panels</td> </tr> <tr> <td>28</td> <td>Safety Screws (ETSSAFETYSCREW)</td> </tr> </tbody> </table>	QTY	DESCRIPTION	3	Assembled ETS Rings	6	Trunk Tubes (ETSCUTTUBE) Refer to supplied documents for tube length.	8	Branch Tubes (ETSCUTTUBE) Refer to supplied documents for tube length.	8	Angle Couplers (ETSANGLECOUPLER)	16	Ring Bolts (ETSRINGBOLT)	16	Ring Nuts (ETSRINGNUT)	7	Tension Couplers (ETSCOUPLER)	8	Tube Connectors (ETSTUBECON)	6	Cable Drops (DROP#G3 and SCRINGHK3)	4	Fabric Panels	28	Safety Screws (ETSSAFETYSCREW)	<table border="1"> <thead> <tr> <th>QTY</th> <th>DESCRIPTION</th> </tr> </thead> <tbody> <tr> <td>4</td> <td>Assembled ETS Rings</td> </tr> <tr> <td>4</td> <td>Trunk Tubes (ETSCUTTUBE) Refer to supplied documents for tube length.</td> </tr> <tr> <td>16</td> <td>Branch Tubes (ETSCUTTUBE) Refer to supplied documents for tube length.</td> </tr> <tr> <td>16</td> <td>Angle Couplers (ETSANGLECOUPLER)</td> </tr> <tr> <td>32</td> <td>Ring Bolts (ETSRINGBOLT)</td> </tr> <tr> <td>32</td> <td>Ring Nuts (ETSRINGNUT)</td> </tr> <tr> <td>10</td> <td>Tension Couplers (ETSCOUPLER)</td> </tr> <tr> <td>16</td> <td>Tube Connectors (ETSTUBECON)</td> </tr> <tr> <td>8</td> <td>Cable Drops (DROP#G3 and SCRINGHK3)</td> </tr> <tr> <td>5</td> <td>Fabric Panels</td> </tr> <tr> <td>40</td> <td>Safety Screws (ETSSAFETYSCREW)</td> </tr> </tbody> </table>	QTY	DESCRIPTION	4	Assembled ETS Rings	4	Trunk Tubes (ETSCUTTUBE) Refer to supplied documents for tube length.	16	Branch Tubes (ETSCUTTUBE) Refer to supplied documents for tube length.	16	Angle Couplers (ETSANGLECOUPLER)	32	Ring Bolts (ETSRINGBOLT)	32	Ring Nuts (ETSRINGNUT)	10	Tension Couplers (ETSCOUPLER)	16	Tube Connectors (ETSTUBECON)	8	Cable Drops (DROP#G3 and SCRINGHK3)	5	Fabric Panels	40	Safety Screws (ETSSAFETYSCREW)
	QTY	DESCRIPTION																																																
	3	Assembled ETS Rings																																																
	6	Trunk Tubes (ETSCUTTUBE) Refer to supplied documents for tube length.																																																
	8	Branch Tubes (ETSCUTTUBE) Refer to supplied documents for tube length.																																																
	8	Angle Couplers (ETSANGLECOUPLER)																																																
	16	Ring Bolts (ETSRINGBOLT)																																																
	16	Ring Nuts (ETSRINGNUT)																																																
	7	Tension Couplers (ETSCOUPLER)																																																
	8	Tube Connectors (ETSTUBECON)																																																
	6	Cable Drops (DROP#G3 and SCRINGHK3)																																																
	4	Fabric Panels																																																
	28	Safety Screws (ETSSAFETYSCREW)																																																
	QTY	DESCRIPTION																																																
4	Assembled ETS Rings																																																	
4	Trunk Tubes (ETSCUTTUBE) Refer to supplied documents for tube length.																																																	
16	Branch Tubes (ETSCUTTUBE) Refer to supplied documents for tube length.																																																	
16	Angle Couplers (ETSANGLECOUPLER)																																																	
32	Ring Bolts (ETSRINGBOLT)																																																	
32	Ring Nuts (ETSRINGNUT)																																																	
10	Tension Couplers (ETSCOUPLER)																																																	
16	Tube Connectors (ETSTUBECON)																																																	
8	Cable Drops (DROP#G3 and SCRINGHK3)																																																	
5	Fabric Panels																																																	
40	Safety Screws (ETSSAFETYSCREW)																																																	
	<ul style="list-style-type: none"> • To install fabric panels on rings, refer to Attach Fabric to Rings (page 15). • To install tubes and angle couplers, refer to Attach Straight Tubes (page 13) and Attach Angle Couplers (page 13). • To tension sections, refer to Tension Tubes (page 14). 																																																	
2.	Locate additional sets of holes (A) on the assembled ETS rings. Align a tube connector with each set of holes and attach with ring nuts and ring bolts (supplied) to assemble the rings. Tube connector must be installed opposite the horizontal leg.																																																	

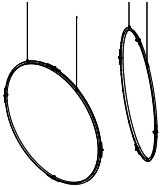
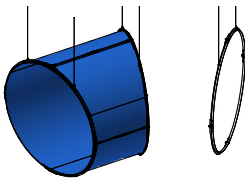
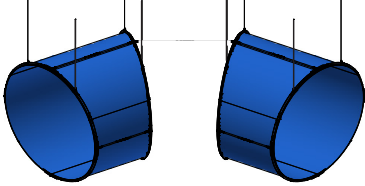
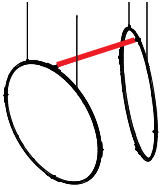
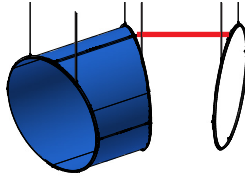
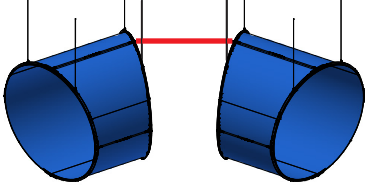
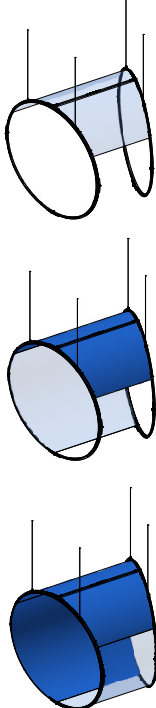
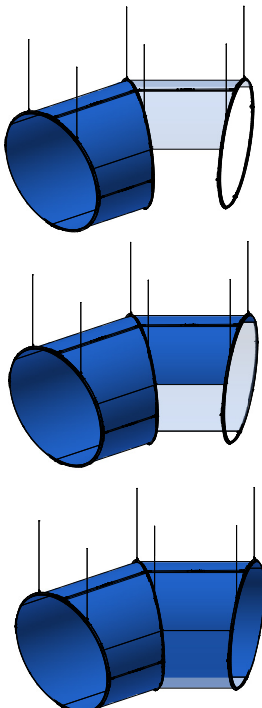
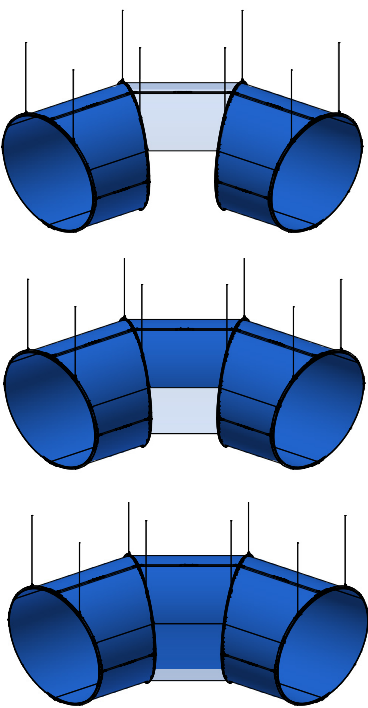
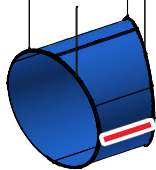
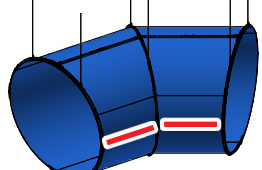
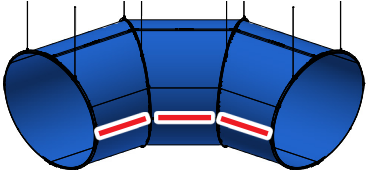
INSTALLATION

Fittings – Tees/Crosses *Continued*

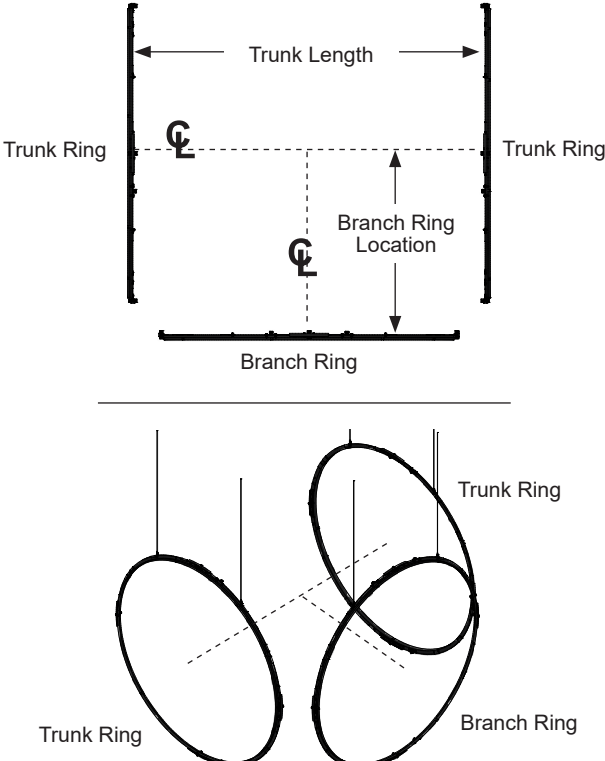
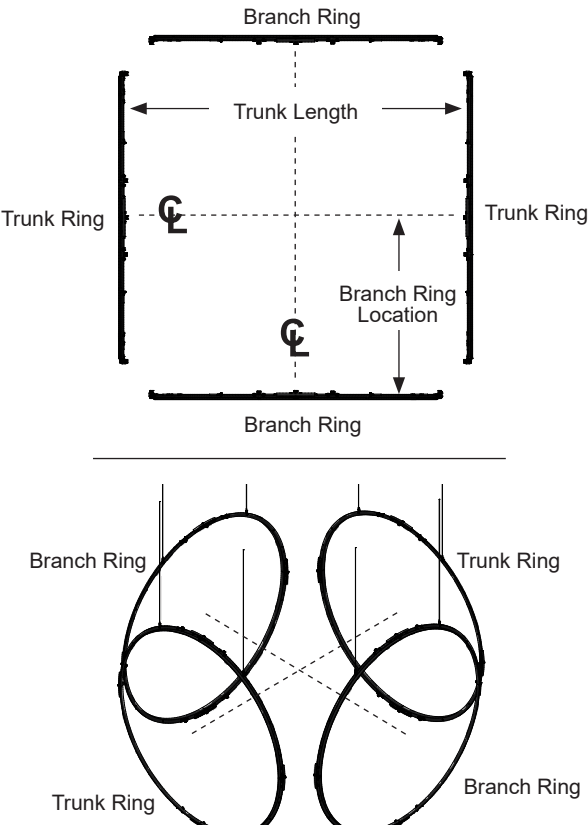
	TEE	CROSS
3.	<p>Hang the rings for the trunk and branch(es). Use the formulas to determine locations.</p> <ul style="list-style-type: none"> • Trunk Length = $\text{Ø} + 24 \text{ in (610 mm)}$ Trunk length is the distance between upstream and downstream trunk rings, measured between vertical flanges. • Branch Ring Location = $(\text{Ø} + 24 \text{ in [610 mm]}) / 2$ Branch ring location is the distance from the centerline to the branch rings. Branch rings are perpendicular to the trunk centerline. 	
<p>Example Ø90 in (2286 mm) ring:</p> <ul style="list-style-type: none"> • Trunk length: $90 \text{ in (2286 mm)} + 24 \text{ in (610 mm)} = 114 \text{ in (2896 mm)}$ • Branch ring location: $(90 \text{ in [2286 mm]} + 24 \text{ in [610 mm]}) / 2 = 57 \text{ in (1448 mm)}$ 		
		

INSTALLATION

Fittings – Tees/Crosses *Continued*

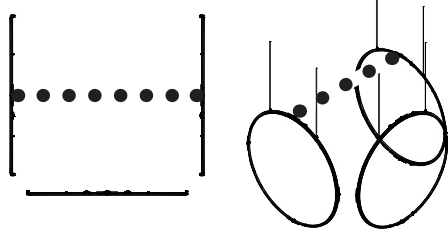
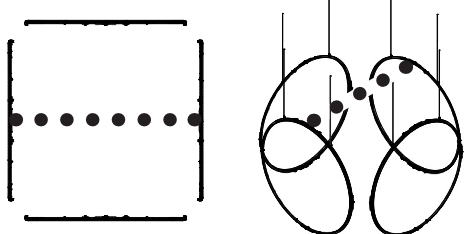
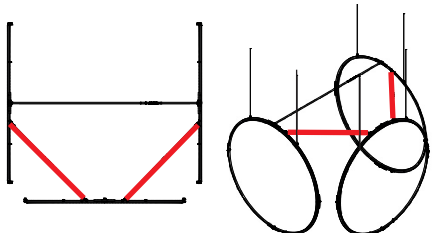
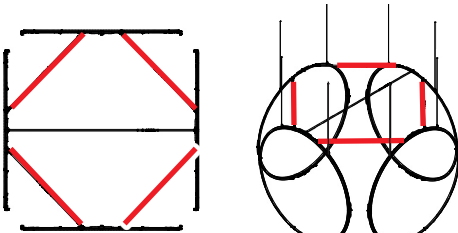
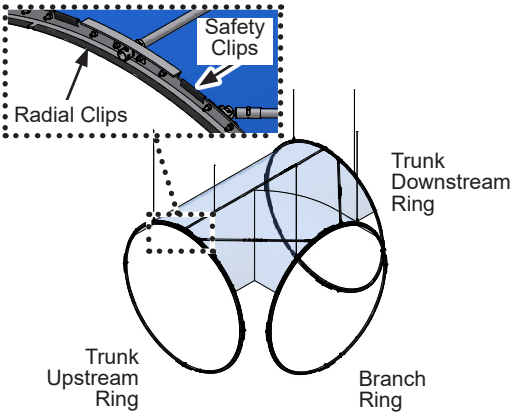
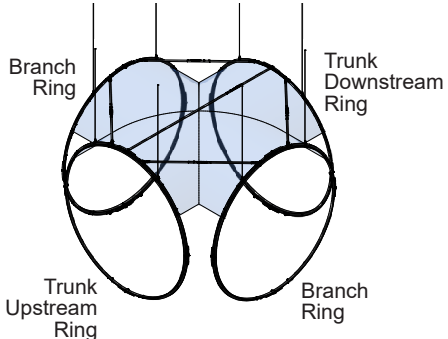
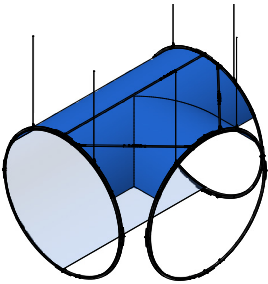
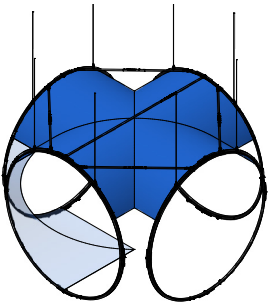
	TEE	CROSS
4.	<p>Install 12:00 trunk tubes. Measure between vertical flanges to set tube length to trunk length. Tubes aligned with the trunk do not require angle couplers. Trunk length is $\text{Ø}+24$ in (610 mm).</p> 	
5.	<p>Install the angle couplers in the upper tube connectors. Install branch tubes.</p> 	
6.	<p>Install the top fabric panel onto the upstream ring using the radial clips and safety clips. Install the radial clips and safety clips onto the downstream ring and branch ring(s).</p> 	
7.	<p>Zip the non-branch lower panel to the top panel. Install the fabric onto the rings with radial clips and safety clips.</p> 	<p>On one branch side, zip the upstream branch panel (labeled R1 or L1) to the top panel. Install fabric to the upstream ring and branch ring with the radial clips and safety clips.</p>  <p>NOTE: Install both panels (R1 + R2 or L1 + L2) on a branch side before installing the fabric panels on the opposite branch side.</p>

INSTALLATION

Fittings – Tees/Crosses *Continued*

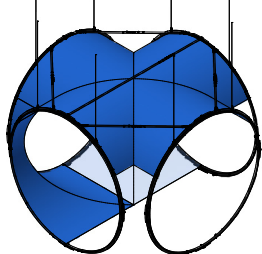
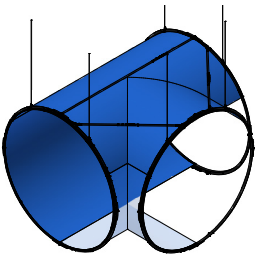
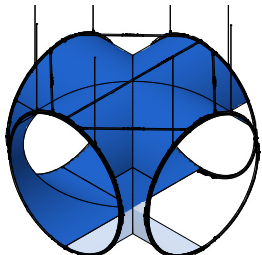
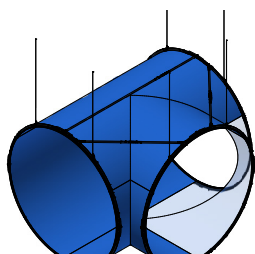
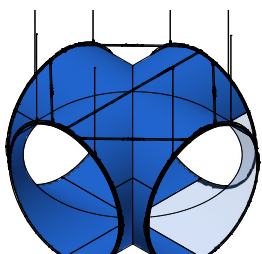
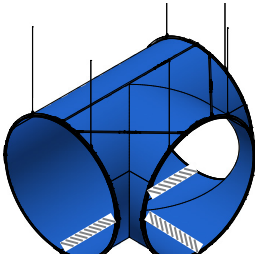
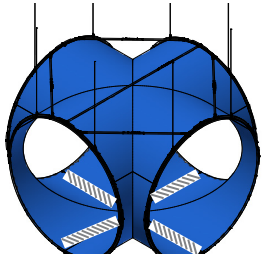
	TEE	CROSS
8.	<p>Not applicable step for tee.</p>	<p>On the same branch side as step 7, zip the downstream branch panel (labeled R2 or L2) to the top panel. Install fabric to the downstream ring and branch ring with the radial clips and safety clips.</p> 
9.	<p>On the branch side, zip the upstream branch panel (labeled R1 or L1) to the top panel. Install fabric to the upstream ring and branch ring using the radial clips and safety clips.</p> 	<p>On the opposite branch side, zip the upstream branch panel (labeled R1 or L1) to the top panel. Install fabric to the upstream ring and branch ring using the radial clips and safety clips.</p> 
10.	<p>On the branch side, zip the downstream branch panel (labeled R2 or L2) to the top panel. Install fabric to the downstream ring and branch ring with the radial clips and safety clips.</p> 	<p>On the same branch side as step 9, zip the downstream branch panel (labeled R2 or L2) to the top panel. Install fabric to the downstream ring and branch ring with the radial clips and safety clips.</p> 
11.	<p>Zip all 6:00 zippers. Install remaining tubes on rings, tension with the tension couplers, and install safety screws.</p> 	<p>Zip all 6:00 zippers. Install remaining tubes on rings, tension with the tension couplers, and install safety screws.</p> 
12.	<p>Make sure all zippers are zipped closed, all clips are attached to the ring, all covers are folded over zippers, and all safety screws are installed. Hang the next section after the fitting. Refer to drawing (supplied).</p>	

INSTALLATION

Fittings – Reducers

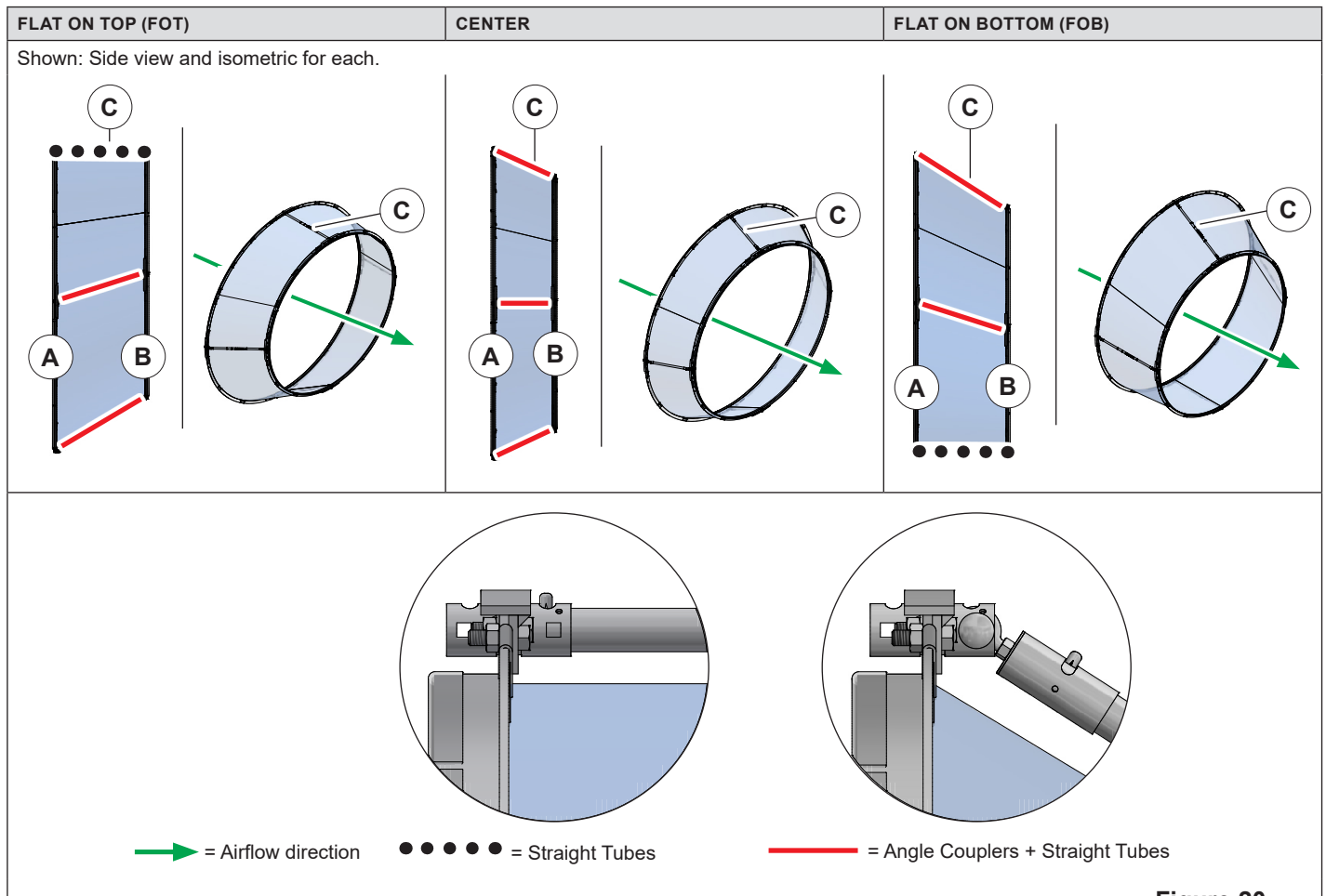

Figure 20

1. Locate required parts:

QTY	DESCRIPTION
2	Assembled ETS Rings (They will be different diameters.)
4-8	Reducer Tubes (ETSCUTTUBE) Refer to supplied documents for tube length.
6-8	Angle Couplers (ETSANGLECOUPLER)
0-4	Tension Couplers (ETSCOUPLER)
3	Fabric Panels
4	Cable Drops (DROP#G3 and SCRINGHK3)
8-16	Safety Screws (ETSSAFETYSCREW)

2. Hang the first ring (A) upstream.
3. Hang the second ring (B) downstream with the flange the opposite direction of the first ring. Hang the rings the distance stated on the drawing(s) (supplied).
4. Install 12:00 tubes (C). Refer to [Attach Straight Tubes \(page 13\)](#) and [Attach Angle Couplers \(page 13\)](#).

INSTALLATION

Fittings – Reducers *Continued*

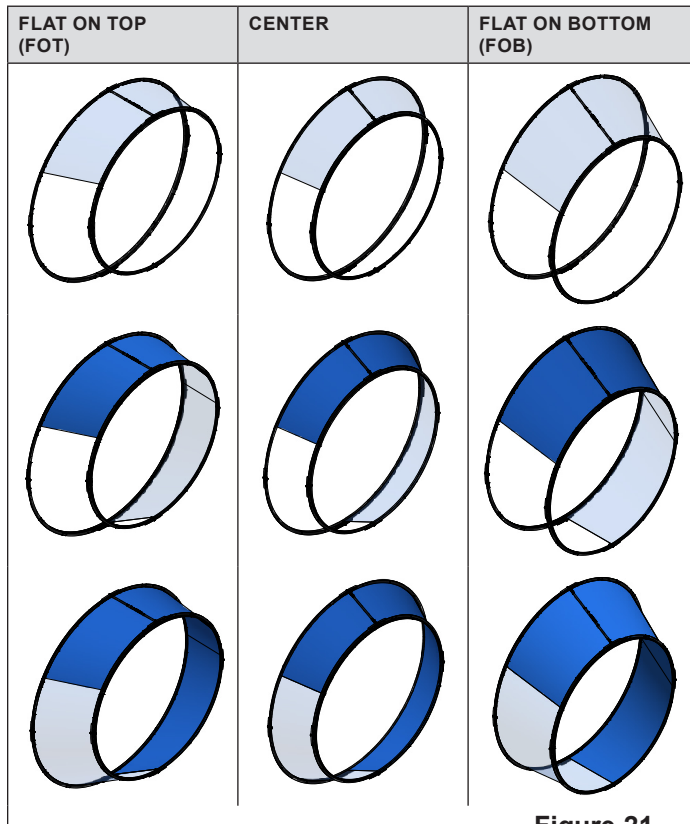

Figure 21

5. Install top panel, then left panel and right panel. Refer to [Attach Fabric to Rings \(page 15\)](#).

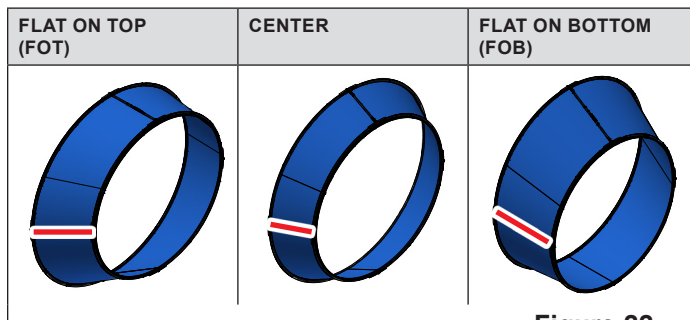

Figure 22

6. Install remaining tubes and tension. Install safety screws. Refer to [Tension Tubes \(page 14\)](#).
7. Make sure that all zippers are zipped closed, all clips are attached to the ring, all covers are folded over zippers, and all safety screws are installed.

INSTALLATION

Fittings – Endcaps

1. Locate required parts:

QTY	DESCRIPTION
1	Assembled ETS Rings
1	Endcap Fabric
2	Cable Drops (DROP#G3 and SCRINGHK3)

2. Hang the ring. Refer to drawing (supplied) for ring orientation.

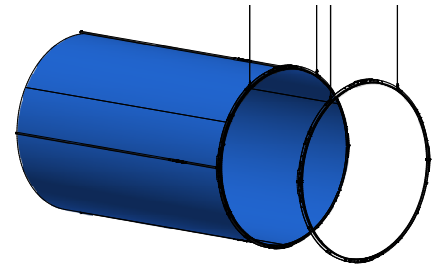

3. Install fabric onto the ring with radial clips and safety clips. Refer to [Attach Fabric to Rings \(page 32\)](#).

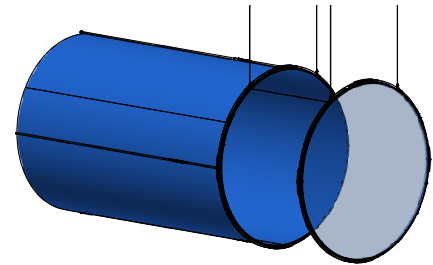

4. Refer to [Install Fabric – Standard End Sections \(page 32\)](#) to complete the section before the endcap.

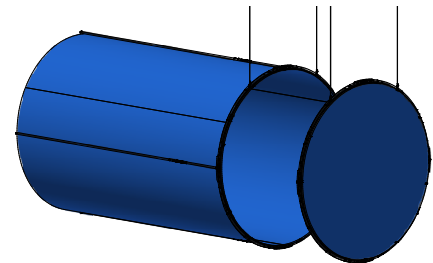

INSTALLATION

Start-Up/Commissioning

Turn on AHU

Turn on the AHU and inflate the DuctSox System.

Make sure that all:

- Sections are inflating correctly.
- Cable drops are plumb.
- Zippers are closed, all clips are attached to the ring, and that all covers are folded over zippers.
- All tubes are tensioned and safety screws are installed.

If lengths do not fit correctly, re-measure all field measurements and compare to project drawings. If all measurements are correct, contact your DuctSox factory representative to discuss options.

Balance Airflow

System must be balanced to design CFM and static pressure immediately after installation.

Most DuctSox systems include a zipper at the inlet location for easy access to monitor airflow.

If the fabric is fluttering after balancing, contact your DuctSox factory representative for solutions to create less turbulent airflow (adjusting the adjustable flow device [AFD] or adding AFDs).

MAINTENANCE

Panel Replacement

To replace a damaged panel or section:

1. Turn off the AHU.
2. Find the tag(s) of the damaged sections and record the job number, tag, section, and panel type. Take photos of the damage for your DuctSox representative.
3. Contact your DuctSox representative with this information to get a replacement made. Your representative will determine if system can continue to operate until a replacement is sent.
4. After a replacement panel or section is received, carefully remove the safety clips and radial clips of the damaged section. Unzip the panel or section from surrounding panels or sections.
5. Replace the panel or section. Refer to **"Installation" (page 7)**
6. Complete **Start-Up/Commissioning (page 31)**.

Cleaning

Launder Fabric

1. Record where each section that will be laundered is installed.
2. Unzip all sections and remove the DuctSox fabric from your system.
3. Obey the wash instructions located on the internal system tags for the DuctSox fabric or complete the remaining steps (that are safe for all DuctSox fabrics).
4. Soak in cold water for 30 minutes.
5. Wash cold, gentle cycle.
6. Rinse fully. Repeat laundering steps if water/DuctSox is still soiled.
7. Drip dry or no-heat tumble dry.

Clean in Place

NOTICE

DO NOT use any chemicals to clean the DuctSox fabric in place.

To clean the DuctSox in place use a vacuum or a dry cloth.

CUSTOMER SERVICE

DUCTSOX WORLD HEADQUARTERS

4343 Chavenelle Road
Dubuque, Iowa 52002

📞 563-588-5300 or 866-382-8769