

Thank you for selecting a fabric duct ventilation system. This Guide should be helpful for installing and cleaning all systems manufactured for a 3x1 Suspension System (only). The 3x1 system is the newest and most simple suspension method.

Sections of Fabric will be labeled, assembled, bagged and boxed for shipping. More complicated systems will include a CAD detail of the system identifying which components are in each package.

CAUTION

Please read all instruction in their entirety prior to beginning installation of any DuctSox System components. Do not install DuctSox system or components until the building construction is completed and site is clean. Installation prior to reading installation manual and completed construction may cause injury during installation and/or damage to your system and could void the product warranty.

INSTALLATION STEPS

Install Cable Components

- 1 Locate Tension Cable and 3x1 Suspension components in shipment. Identify 3x1 Hanger size by using the Sizing Reference Table to the right. Tension Cable includes listed components below plus cable supports (5 ft standard).

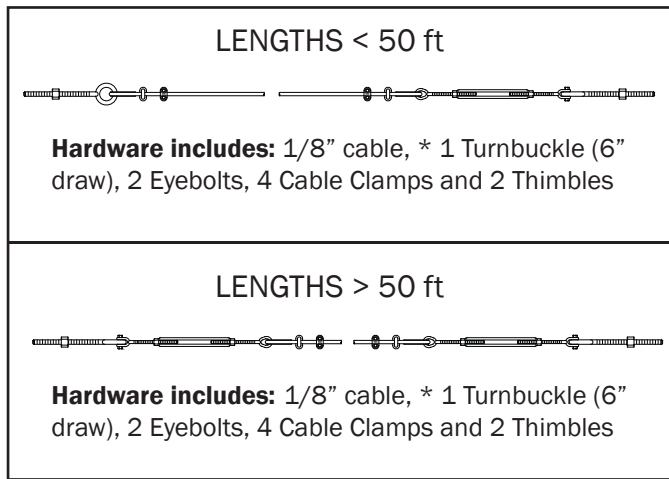

* Cable Length = DuctSox Length + 20 ft (per straight)

3x1 Sizing Reference Table

DuctSox Diameter	Hanger Width
10" to 12"	14 5/8"
14" to 16"	18 1/8"
18" to 20"	21 1/2"
22" to 24"	25 1/8"
26" to 28"	28 3/8"
30" to 32"	31 7/8"
34" to 36"	35 3/8"
38" to 40"	39"
42" to 44"	42 1/2"
46" to 48"	46"



- 2 Install cable and supports. Cable should be 3" above top of duct. Construct support brackets for 100 to 150 lbs. cable tension. Position cable start/stop nearest the inlet and at least 18" past endcap of any straight section. Locate 3x1 Hangers per section and loosely position with 36" spacing.

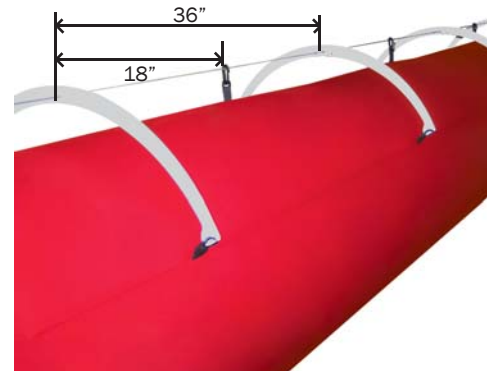
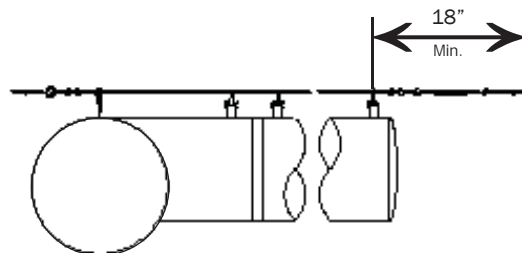

Install Fabric Duct

3 Use the following illustration to attach the fabric to the 3x1 Hanger and Tension Cable.

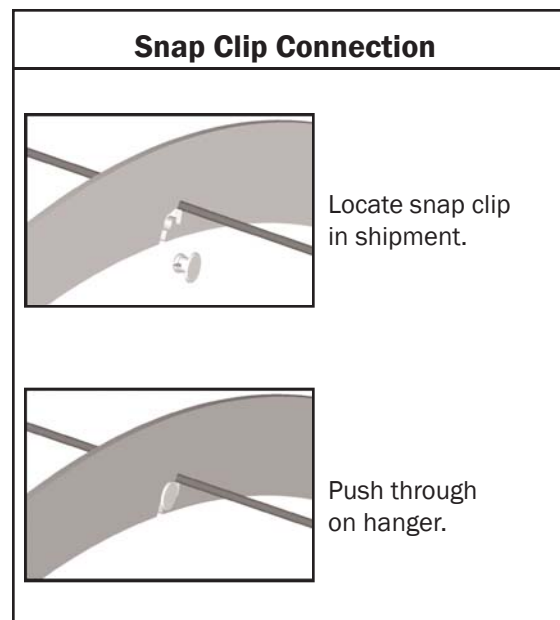
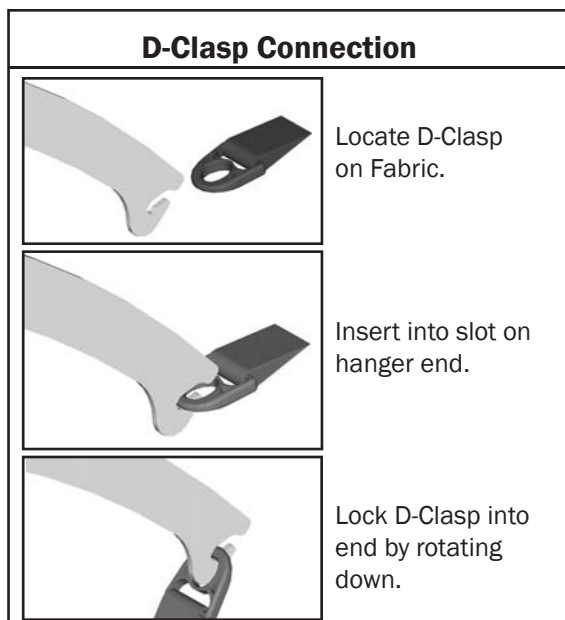
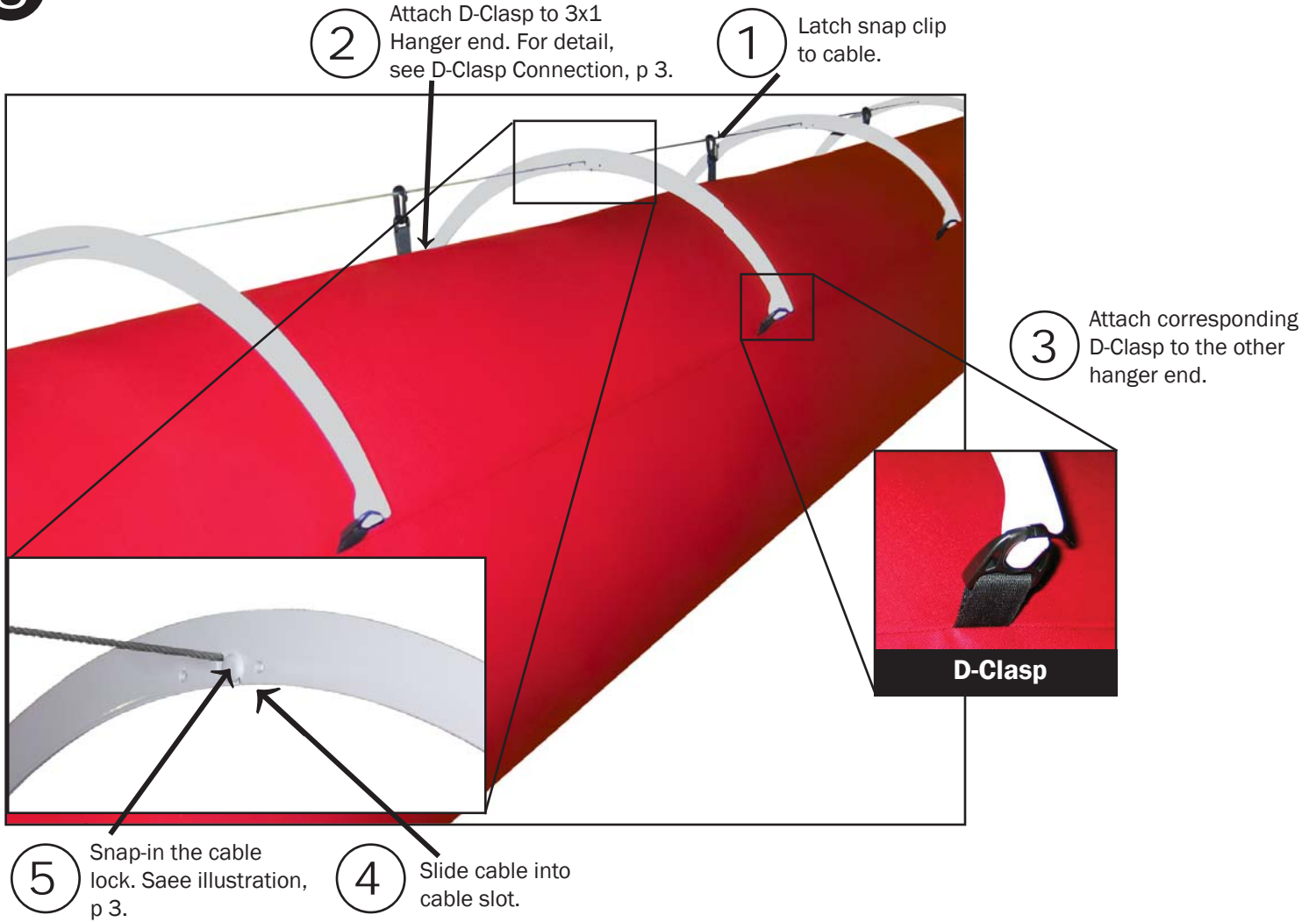

Attach cable drop supports as needed using loop end and Gripple Quick Connection (see illustration below).

Used to reduce cable sag - install every 12'-6" or as needed to maintain a cable sag less than 6 inches.

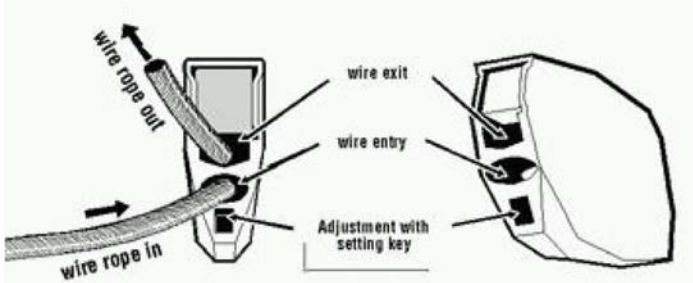
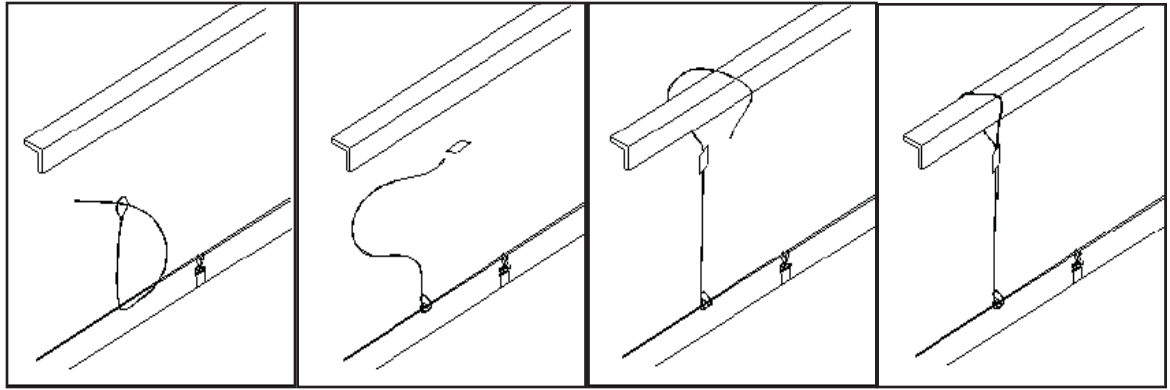

Note: Fittings may require additional cable supporting brackets for elbows and take-off's. For best results, verify details on all fittings before determining cable end locations.

Connect to Metal Outlet Collar

- Fabric is mfg. 1/2" larger than specified to fit over metal duct.
- Collar length should be 6"-10" for secure fabric attachment.
- Edge guard (provided) should be installed on the edge to reduce fabric wear.

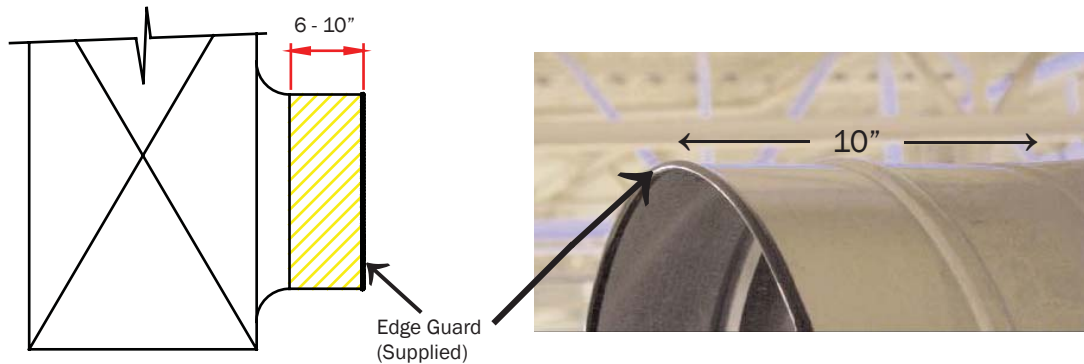

Slide fabric inlet over collar and position the zipper start/stop at TOP CENTER and Tighten the duct belt.

Secure Anchors with standard screws (not provided) after start-up (to ensure proper inflated alignment).



Start Up Ductsox System

- 1** Turn on the AHU to inflate DuctSox System.
- 2** Check all snaps and sections to ensure system is inflating properly. If required - move snaps and/or 3x1 Hangers to eliminate puckering at binding locations.
- 3** Once system is properly adjusted, deflate the system, pull the last snap in each straight section and secure tension using cable clamp to cable (will reduce inflation "popping"). If the system includes elbows secure the last snap before elbow(s).



Final Fitment/Inspection

After startup, these few extra steps ensure a quality installation:

- Tension Cable does not sag more than 6" (if so, add tension or cable support drops)
- Confirm 3x1 Hangers properly supporting fittings (elbow or take-off)
- Inlet connection is uniform with DuctSox (not rotated)
- Verify zippers are all closed and overlaps are in place

Verify 3x1 Hangers installed properly for fittings

- 2 Hangers Per Elbow (45 +degrees)
- 1 Hanger Per Outlet Tee
- 0 Hangers Per Transition

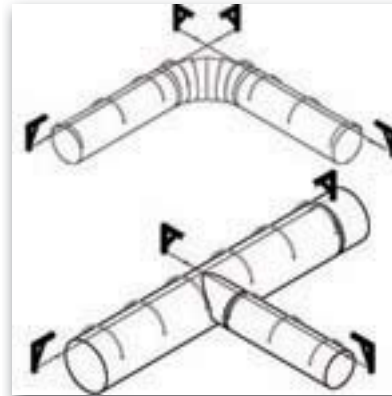

Balance Airflow

System must be balanced to design CFM and static pressure immediately after installation. Most DuctSox systems include a zipper at the inlet location for easy access to monitor flow.

NOTE: If the fabric is fluttering after balancing, please contact the factory immediately. Solutions to the fluttering include adjusting the Adjustable Flow Device (AFD), adding AFD's or other tasks that would result in laminar airflow.

DuctSox Final Filter® - If included, will be assembled with DuctSox system and should be positioned at the first zipper at the inlet of the DuctSox run. If the equipment/fabric duct is running during construction, a Merv 8 construction filter may be helpful in reducing dust/dirt build up.

Installation questions? Please, consult your support team. (866) DuctSox (382-8769).

DUCTSOX®
Fabric Air Dispersion Products

4343 Chavenelle Road
Dubuque, IA 52002-2654
www.ductsox.com